

SPECIFICATIONS	Model	80C25.5-CR									
		C(CR)-series 5.5kW, 3-phase									
<p><b>Type of Pump</b> Submersible cast iron pump with a cutting device suitable for pumping sewage and wastewater</p> <p><b>Type of Fluid</b> Sewage, wastewater, and water carrying solid matters</p> <p>Temperature: 0 to 40°C (High temperature model available on special request)</p> <p><b>Discharge Bore</b> 80mm</p> <p><b>Motor Output</b> 5.5kW</p> <p><b>Power Supply</b> Three-phase</p> <p><b>Starting Method</b> Direct on Line (Star-Delta available on special request)</p> <p><b>Motor</b> Continuous-duty rated, dry-type induction motor</p> <p>Insulation Class: F Degree of Protection: IP68</p> <p>No. of Poles &amp; Speed (Synchronous Speed) 2-pole, 3000/3600min<sup>-1</sup> (50/60Hz)</p> <p>Power Supply Voltages &amp; Rated Currents</p> <table border="0"> <tr> <td>50Hz</td> <td>60Hz</td> </tr> <tr> <td>380V – 12.0A</td> <td>220V – 21.7A</td> </tr> <tr> <td>400V – 11.6A</td> <td>380V – 11.8A</td> </tr> <tr> <td>415V – 11.4A</td> <td>440V – 10.9A</td> </tr> </table> <p><b>Power Cable</b> Sheath: Chloroprene rubber Standard Length: 10m 200 to 600V supply: 1 × 4 × 3.5mm<sup>2</sup>, O.D. 14.1mm</p> <p><b>Dry Weight</b> (excluding cable) Free Standing Type: 136.5kg Guide Rail Fitting Type: 123kg</p>		50Hz	60Hz	380V – 12.0A	220V – 21.7A	400V – 11.6A	380V – 11.8A	415V – 11.4A	440V – 10.9A	<p><b>Impeller</b> Semi-open two-channel impeller for solid-handling design, made of high-chromium cast iron, dynamically balanced. A sintered tungsten carbide alloy edge is blazed on each impeller vane.</p> <p>Solids Passage 50Hz – 29 × 23.2mm 60Hz – 29 × 23 mm</p> <p><b>Cable Entry with Anti-Wicking Block</b> Watertight cable entry with strain-relief device. The anti-wicking block prevents water incursion due to capillary action should the power cable be damaged or the end submerged.</p> <p><b>Bearings</b> Permanently lubricated, deep-groove, double-shielded C3 ball bearings</p> <p><b>Shaft</b> 420 stainless steel</p> <p><b>Shaft Seal (Mechanical Seal)</b> Furnished with a double-face mechanical seal located in oil chamber. Both upper and lower seal faces always run in a clean environment.</p> <p>Upper Seal Faces: SiC + SiC Lower Seal Faces: SiC + SiC</p> <p><b>Oil Seal (Lip Seal)</b> Used as a “Dust Seal”, it protects the mechanical seal from abrasive particles.</p> <p><b>Pressure Relief Port</b> Protects the mechanical seal from over rated limits, and also protects the seal faces from abrasive particles by drawing particles away.</p> <p><b>OIL LIFTER (Patented)</b> Equipped in oil chamber. It forcibly supplies lubricating oil to the mechanical seal and continues to supply the oil to the upper seal faces even if lubricant falls below the rated volume.</p> <p>Type of Lubricating Oil &amp; Volume Turbine Oil (ISO VG32), 2240ml</p> <p><b>Motor Protection Device</b> A circle thermal protector built in the motor housing. Directly cuts the motor circuit if excessive heat builds up or an overcurrent condition occurs in the motor.</p>	
50Hz	60Hz										
380V – 12.0A	220V – 21.7A										
400V – 11.6A	380V – 11.8A										
415V – 11.4A	440V – 10.9A										
<p><b>Optional Accessories</b></p> <table border="0"> <tr> <td> <p><b>Bend Set</b> (Free Standing Type)</p> <ul style="list-style-type: none"> <li>• Discharge Bend</li> <li>• JIS 10kg/cm<sup>2</sup> Screwed Flange</li> </ul> <p><b>Stand Set</b> (Free Standing Type)</p> <ul style="list-style-type: none"> <li>• Stand</li> </ul> </td> <td> <p><b>TOS Set</b> (Guide Rail Fitting Type)</p> <ul style="list-style-type: none"> <li>• Duckfoot Bend</li> <li>• Guide Support</li> <li>• Guide Hook</li> <li>• Lifting Chain 5m (with Shackles)</li> <li>• JIS 10kg/cm<sup>2</sup> Screwed Flange</li> </ul> <p><b>External Leakage Sensor</b></p> </td> </tr> </table>				<p><b>Bend Set</b> (Free Standing Type)</p> <ul style="list-style-type: none"> <li>• Discharge Bend</li> <li>• JIS 10kg/cm<sup>2</sup> Screwed Flange</li> </ul> <p><b>Stand Set</b> (Free Standing Type)</p> <ul style="list-style-type: none"> <li>• Stand</li> </ul>	<p><b>TOS Set</b> (Guide Rail Fitting Type)</p> <ul style="list-style-type: none"> <li>• Duckfoot Bend</li> <li>• Guide Support</li> <li>• Guide Hook</li> <li>• Lifting Chain 5m (with Shackles)</li> <li>• JIS 10kg/cm<sup>2</sup> Screwed Flange</li> </ul> <p><b>External Leakage Sensor</b></p>						
<p><b>Bend Set</b> (Free Standing Type)</p> <ul style="list-style-type: none"> <li>• Discharge Bend</li> <li>• JIS 10kg/cm<sup>2</sup> Screwed Flange</li> </ul> <p><b>Stand Set</b> (Free Standing Type)</p> <ul style="list-style-type: none"> <li>• Stand</li> </ul>	<p><b>TOS Set</b> (Guide Rail Fitting Type)</p> <ul style="list-style-type: none"> <li>• Duckfoot Bend</li> <li>• Guide Support</li> <li>• Guide Hook</li> <li>• Lifting Chain 5m (with Shackles)</li> <li>• JIS 10kg/cm<sup>2</sup> Screwed Flange</li> </ul> <p><b>External Leakage Sensor</b></p>										
TSURUMI MANUFACTURING CO., LTD.											

NO. J4-34352-1

# PUMP PERFORMANCE CURVES

TYPE	Submersible High Head Cutter Sewage Pump	MODEL	80C25.5-CR-51 TOS80C25.5-CR-51	FREQUENCY	50 Hz
------	---	-------	-----------------------------------	-----------	-------

CUSTOMER'S NAME \_\_\_\_\_

EQUIPMENT TITLE \_\_\_\_\_ NO. \_\_\_\_\_

	STANDARD SPECIFICATIONS	REQUIRED SPECIFICATIONS
DISCHARGE BORE	mm	80 mm
TOTAL HEAD	m	Max. 32 m
CAPACITY	m <sup>3</sup> /min	Max. 1.34 m <sup>3</sup> /min
MOTOR OUTPUT	kW	5.5 kW
PHASE × VOLTAGE	φ × V	3 φ × V
CURRENT	A	A
POLES / REVOLUTION	P / min <sup>-1</sup>	2 P / S. S. 3000 min <sup>-1</sup>
STARTING METHOD		DIRECT ON LINE
INSULATION CLASS		F

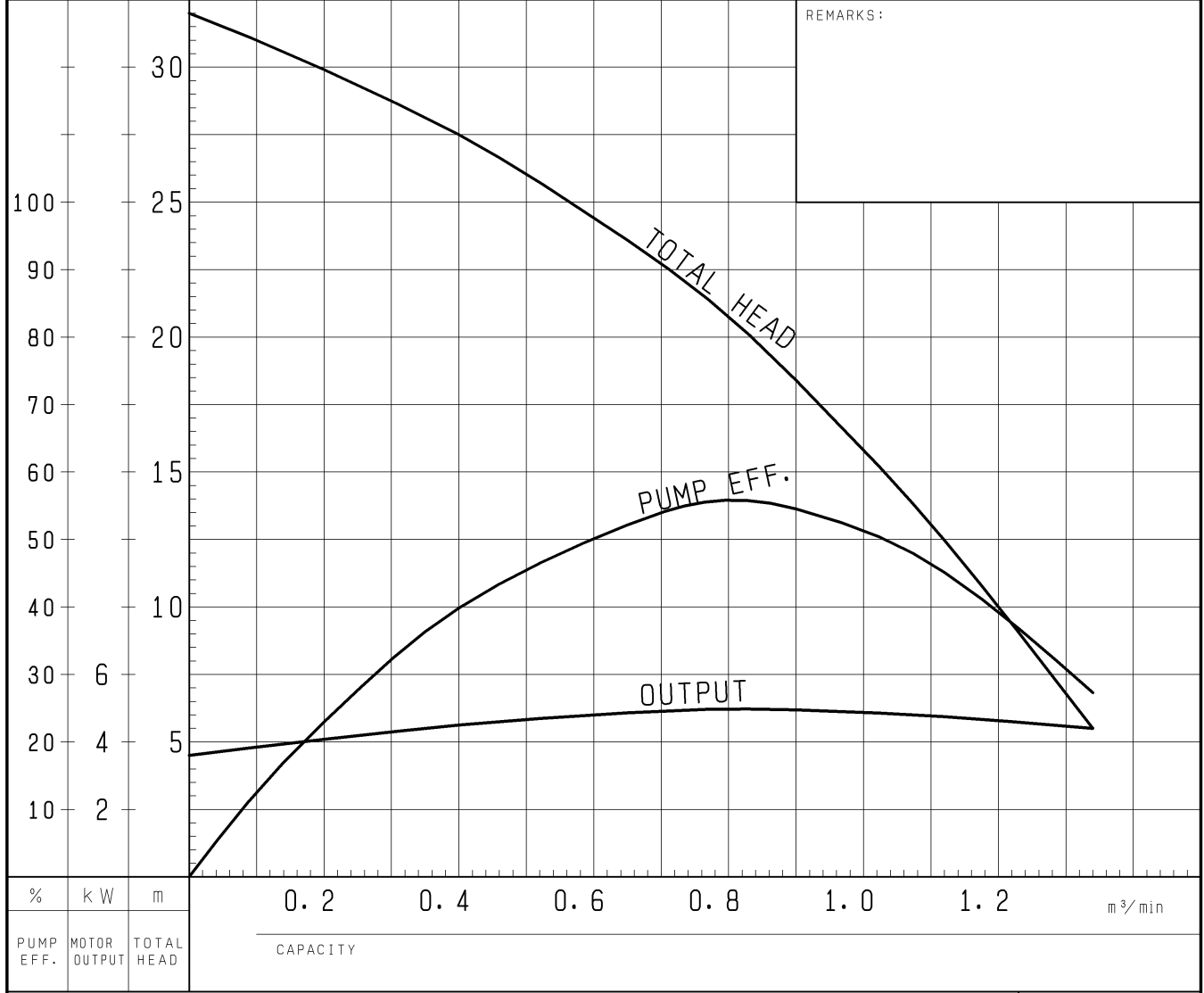

TSURUMI MFG. CO., LTD.

<b>DIMENSION DRAWING</b>		No.	No. J4-34350-1
TYPE	Submersible High Head Cutter Sewage Pump	MODEL	80C25.5-CR -51/61 80C27.5-CR -51/61

Approximate Weight (※)			
	Discharge Bend	Stand	Pump
5.5kW	12kg	4.5kg	120kg
7.5kW	12kg	4.5kg	125kg

※excluding cable  
250

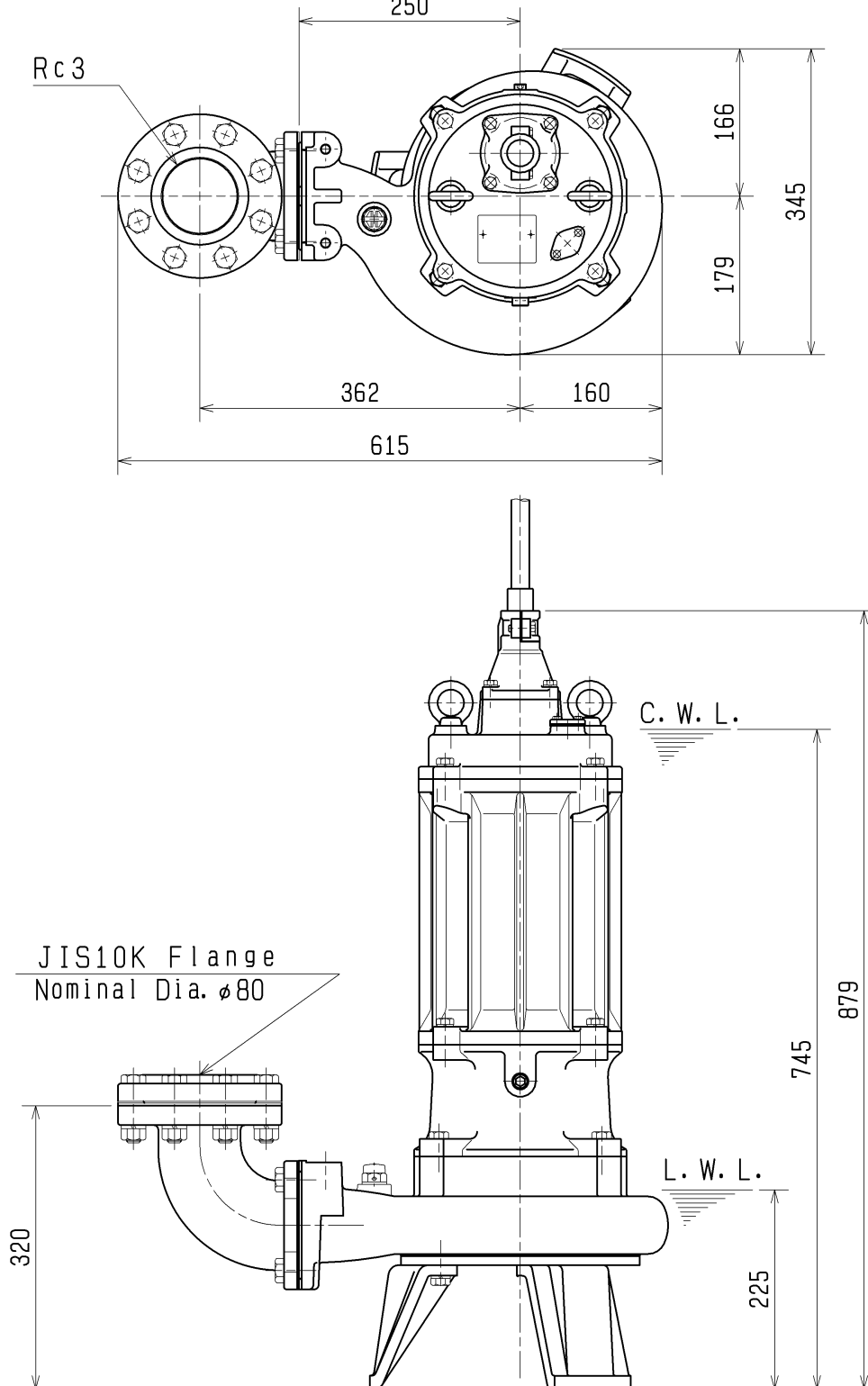

C. W. L. :Continuous Running Water Level  
L. W. L. :Lowest Running Water Level

<b>SECTIONAL DRAWING</b>		No.	No. J4-34351-1
TYPE	Submersible High Head Cutter Sewage Pump	MODEL	80C25.5-CR -51/61

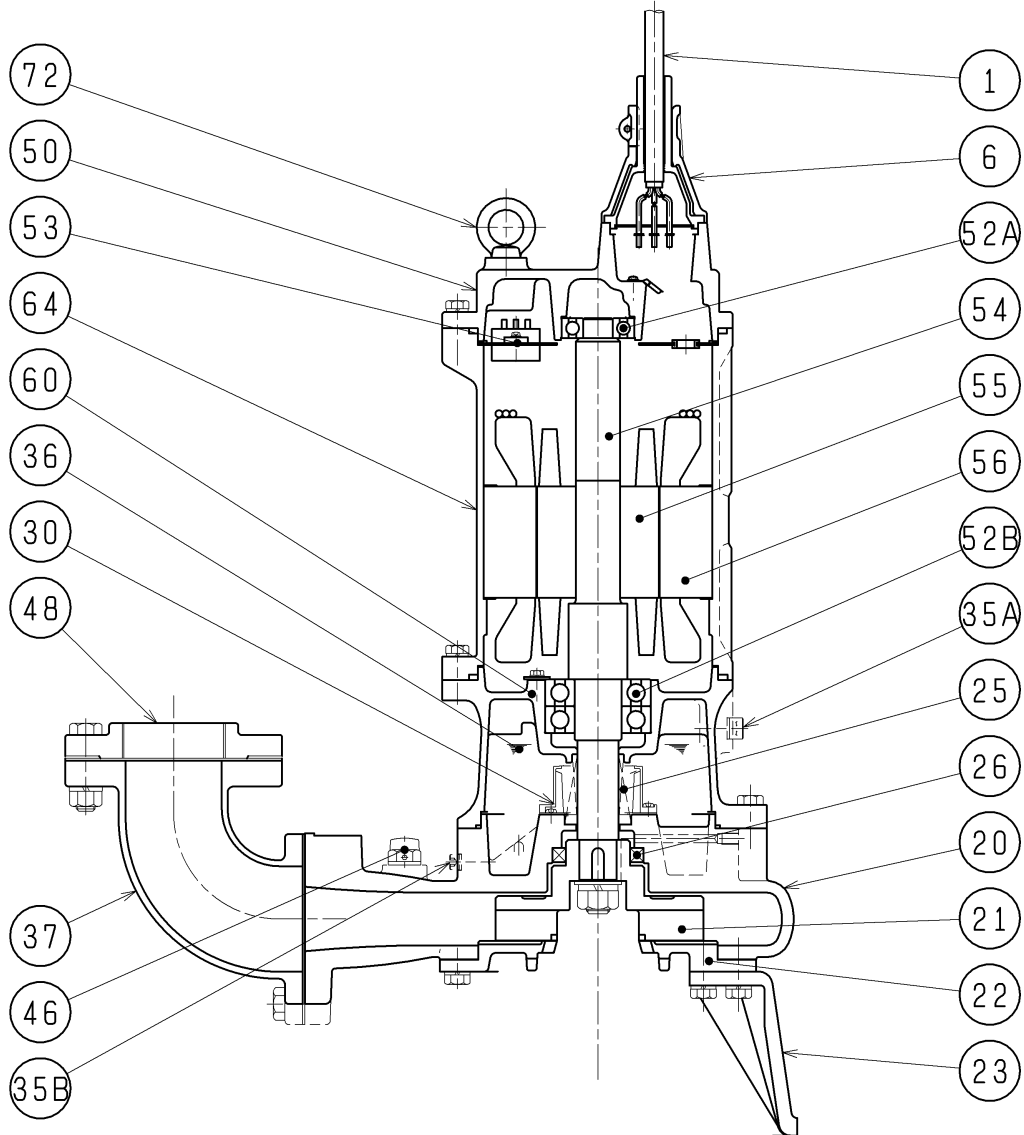

REQ. SPECIFICATION

No.	DESCRIPTION	Q'TY	MATERIAL / NOTE	No.	DESCRIPTION	Q'TY	MATERIAL / NOTE
1	Cabtyre Cable	1	Chloroprene Sheath	48	Screwed Flange	1	Gray Iron Casting
6	Stuffing Box	1	Gray Iron Casting	50	Motor Bracket	1	Gray Iron Casting
20	Pump Casing	1	Gray Iron Casting	52A	Upper Bearing	1	6305ZZC3
21	Impeller	1	Chromiun Iron Casting (WC Edge)	52B	Lower Bearing	1	6308ZZD2C3
22	Suction Cover	1	Chromiun Iron Casting	53	Motor Protector	1	
23	Stand	3	Gray Iron Casting	54	Shaft	1	Stainless Steel 420J2
25	Mechanical Seal	1	H-35	55	Rotor	1	
26	Oil Seal	1	TC557812	56	Stator	1	
30	Oil Lifter	1	Plastic	60	Bearing Housing	1	Gray Iron Casting
35A	Oil Plug	1	Stainless Steel 304	64	Motor Frame	1	Gray Iron Casting
35B	Oil Plug	1	Stainless Steel 304	72	Eye Bolt	2	Structure Steel
36	Lubricant		Turbine Oil (ISO VG32)				
37	Discharge Bend	1	Gray Iron Casting				
46	Air Release Valve	1	Nylon				