

SPECIFICATIONS	Model	KRS(Slurry)-series							
	KRS2-150	9kW, 3-phase							
<p>Type of Pump Submersible slurry pump for construction and foundation works, mining, and quarries, etc.</p> <p>Type of Fluid Water containing sand, mud, and slurry</p> <p>Temperature: 0 to 40°C (High temperature model available on special request)</p> <p>Discharge Bore & Connection 150mm, Hose Coupling</p> <p>Motor Output 9kW</p> <p>Power Supply Three-phase</p> <p>Starting Method Direct on Line (Star-Delta available on special request)</p> <p>Motor Continuous-duty rated, dry-type induction motor</p> <p>Insulation Class: B Degree of Protection: IP68</p> <p>No. of Poles & Speed (Synchronous Speed) 4-pole, 1500/1800min⁻¹ (50/60Hz)</p> <p>Power Supply Voltages & Rated Currents</p> <table border="0"> <tr> <td>50Hz</td> <td>60Hz</td> </tr> <tr> <td>380V – 19.5A</td> <td>220V – 33.0A</td> </tr> <tr> <td>400V – 18.5A</td> <td>380V – 19.1A</td> </tr> <tr> <td>415V – 18.0A</td> <td>440V – 16.5A</td> </tr> </table> <p>Power Cable Sheath: Chloroprene rubber Standard Length: 8m 380 to 600V supply: 1 x 4 x 5.5mm², O.D. 19.8mm 200 to 240V supply: 1 x 4 x 8.0mm², O.D. 21.7mm</p> <p>Dry Weight (excluding cable) 170kg</p>	50Hz	60Hz	380V – 19.5A	220V – 33.0A	400V – 18.5A	380V – 19.1A	415V – 18.0A	440V – 16.5A	<p>Impeller Semi-open Impeller made of high-chromium cast iron</p> <p>Solids Passage 50Hz – ϕ30mm 60Hz – ϕ30mm</p> <p>Agitator High-chromium cast iron</p> <p>Suction Plate Made of high-chromium cast iron, excellent in abrasion-resistance</p> <p>Cable Entry with Anti-Wicking Block Watertight cable entry with strain-relief device. The anti-wicking block prevents water incursion due to capillary action should the power cable be damaged or the end submerged.</p> <p>Bearing Permanently lubricated, deep-groove, double-shielded C3 ball bearings</p> <p>Shaft 420 stainless steel</p> <p>Shaft Seal (Mechanical Seal) Furnished with a double-face mechanical seal located in oil chamber. Both upper and lower seal faces always run in a clean environment.</p> <p>Upper Seal Face: SiC + SiC Lower Seal Face: SiC + SiC</p> <p>Oil Seal (Lip Seal) Used as a "Dust Seal"; it protects the mechanical seal from abrasive particles.</p> <p>OIL LIFTER (Patented) Equipped in oil chamber. It forcibly supplies lubricating oil to the mechanical seal and continues to supply the oil to the upper seal faces even if lubricant falls below the rated volume.</p> <p>Type of Lubricating Oil & Volume Turbine Oil (ISO VG32), 2300ml</p> <p>Motor Protection Device A circle thermal protector built in the motor housing. Directly cuts the motor circuit if excessive heat builds up or an overcurrent condition occurs in the motor.</p>
50Hz	60Hz								
380V – 19.5A	220V – 33.0A								
400V – 18.5A	380V – 19.1A								
415V – 18.0A	440V – 16.5A								
TSURUMI MANUFACTURING CO., LTD.									

NO. A-22026-1

PUMP PERFORMANCE CURVES

TYPE Submersible Slurry Pump	MODEL KRS2-150	FREQUENCY 50 Hz
---------------------------------	-------------------	--------------------

CUSTOMER'S NAME _____

EQUIPMENT TITLE _____ NO. _____

	STANDARD SPECIFICATIONS	REQUIRED SPECIFICATIONS
DISCHARGE BORE	150 mm	mm
TOTAL HEAD	15 / 8 m	m
CAPACITY	1.8 / 2.5 m ³ /min	m ³ /min
MOTOR OUTPUT	9.0 kW	kW
PHASE × VOLTAGE	3 φ × V	φ × V
CURRENT	A	A
POLES / REVOLUTION	4 P / S. S. 1500 min ⁻¹	P / min ⁻¹
STARTING METHOD	DIRECT ON LINE	
INSULATION CLASS	B	

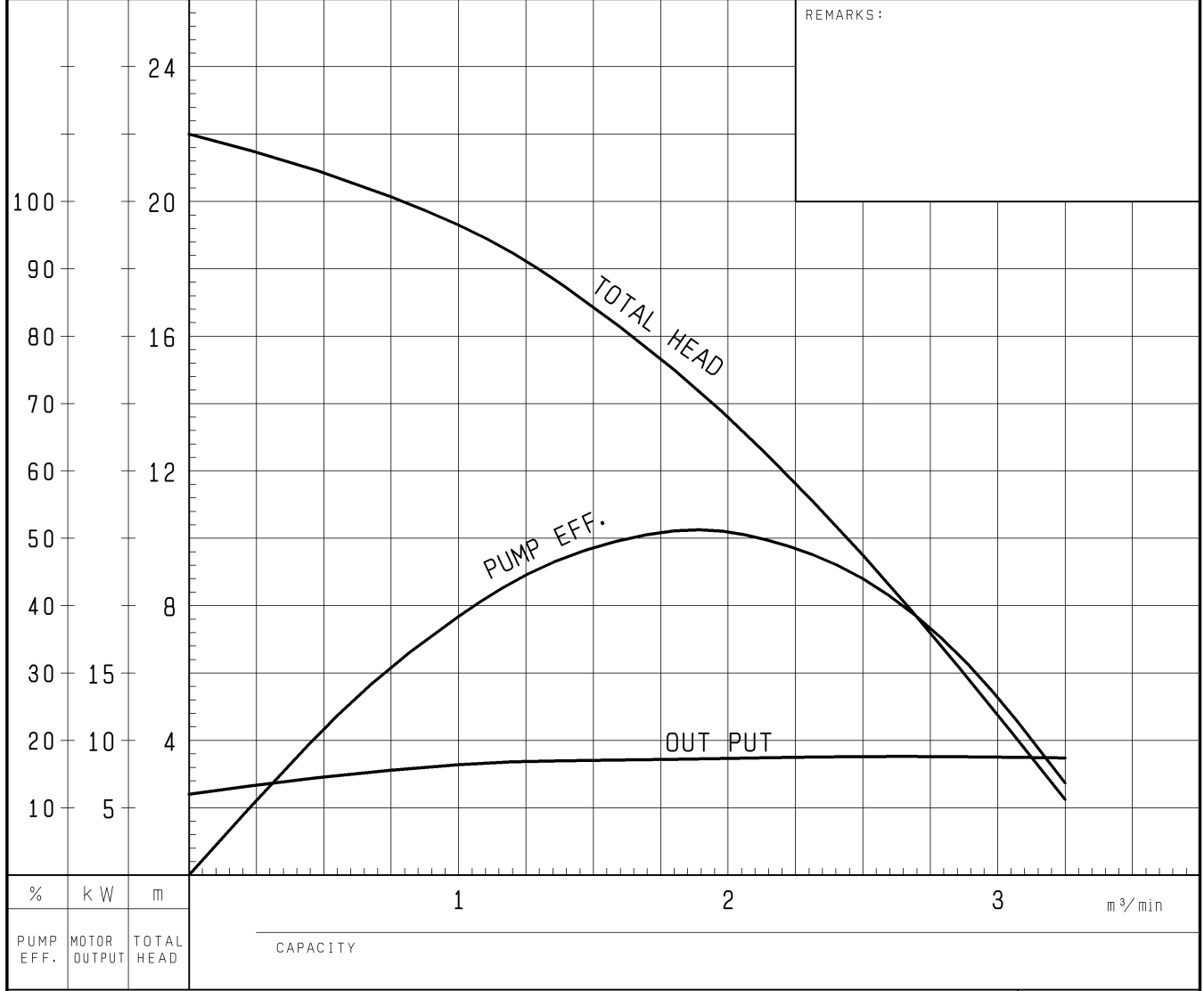

TSURUMI MFG. CO., LTD.

DIMENSION DRAWING		No.	No. A-22030-1
TYPE	Submersible Slurry Pump	MODEL	KRS2-150

Approximate Weight (※)	
50Hz	60Hz
170kg	162kg

※excluding cable

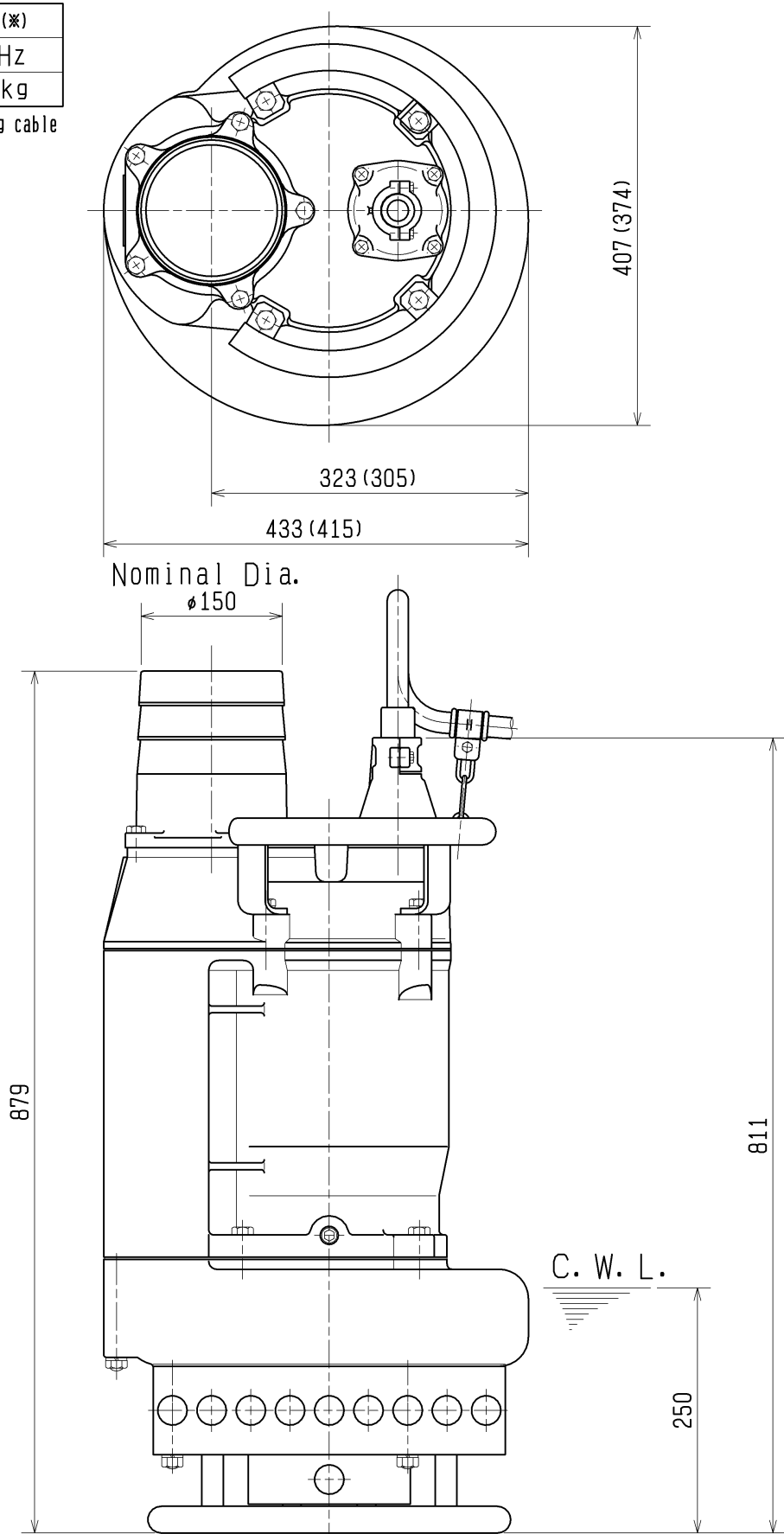

The Figure in () shows the dimensions of 60Hz.

C. W. L. :Continuous running Water Level

SECTIONAL DRAWING		No.	No. A-22033-1
TYPE	Submersible Slurry Pump	MODEL	KRS2-150

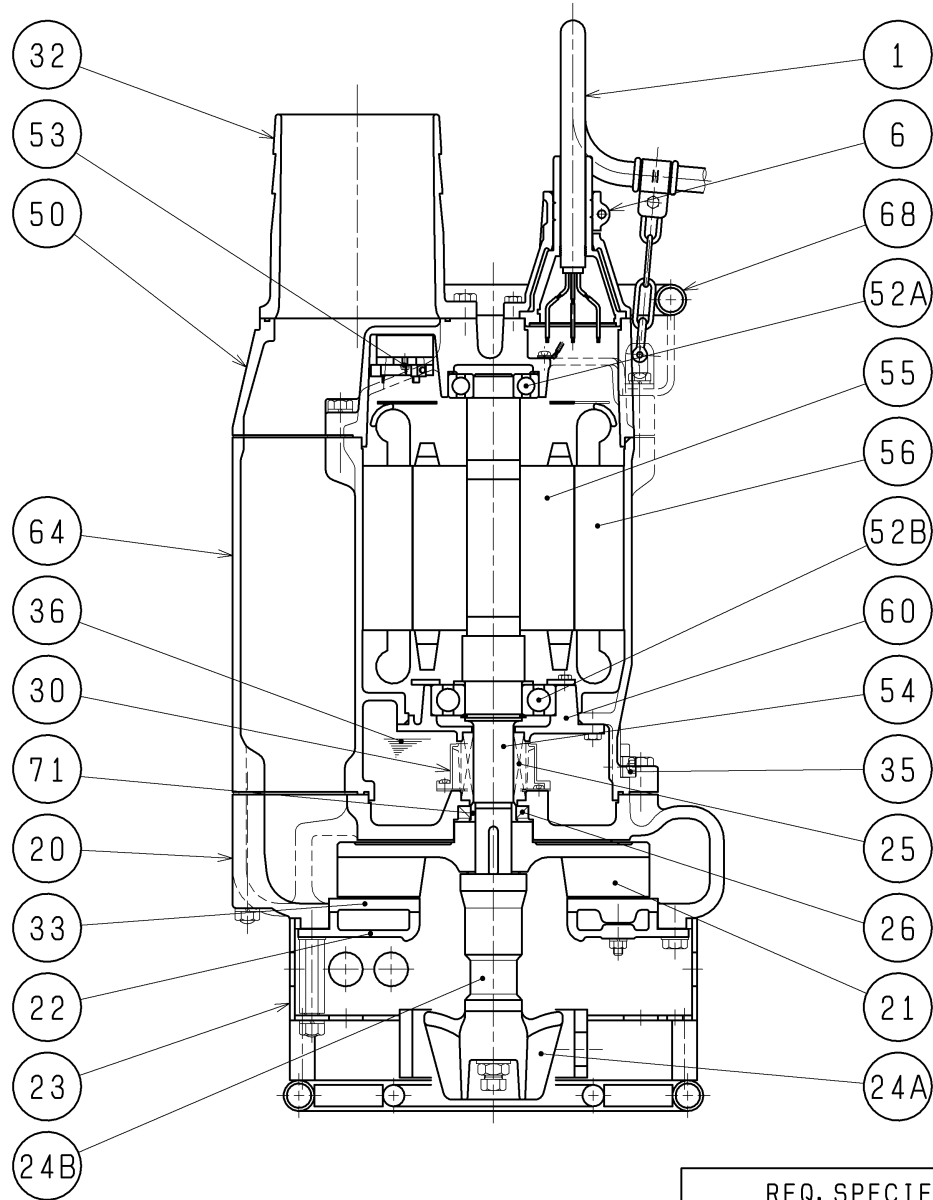

REQ. SPECIFICATION

No.	DESCRIPTION	Q'TY	MATERIAL / NOTE	No.	DESCRIPTION	Q'TY	MATERIAL / NOTE
1	Cable	1	Chloroprene Sheath	36	Lubricant		Turbine Oil (ISO VG32)
6	Stuffing Box	1	Gray Iron Casting	50	Motor Bracket	1	Gray Iron Casting
20	Pump Casing	1	Gray Iron Casting	52A	Upper Bearing	1	6307ZZC3
21	Impeller	1	Chromium Iron Casting	52B	Lower Bearing	1	6310ZZC3
22	Suction Cover	1	Gray Iron Casting	53	Motor Protector	1	
23	Strainer Stand	1	Steel Sheet & Carbon Steel Pipe	54	Shaft	1	Stainless Steel 420J2
24A	Agitator	1	Chromium Iron Casting	55	Rotor	1	
24B	Connecting Rod	1	Malleable Iron Casting (Quenching)	56	Stator	1	
25	Mechanical Seal	1	H-35	60	Bearing Housing	1	Gray Iron Casting
26	Oil Seal	1	TC406211	64	Motor Frame	1	Gray Iron Casting
30	Oil Lifter	1	Plastic	68	Handle	1	Steel Sheet & Carbon Steel Pipe
32	Hose Coupling	1	Gray Iron Casting	71	Shaft Sleeve	1	Stainless Steel 403
33	Suction Plate	1	Chromium Iron Casting				
35	Oil Plug	1	Stainless Steel 304				