

SPECIFICATIONS	Model	NKZ3-100H	NKZ-series						
			11kW, 3-phase						
<p>Type of Pump Submersible slurry pump for construction and foundation works, mining, and quarries, etc.</p> <p>Type of Fluid Water containing sand, mud, and slurry</p> <p>Temperature: 0 to 40°C (High temperature model available on special request)</p> <p>Discharge Bore & Connection 100mm, Hose Coupling</p> <p>Motor Output 11kW</p> <p>Power Supply Three-phase</p> <p>Starting Method Direct on Line (Star-Delta available on special request)</p> <p>Motor Continuous-duty rated, dry-type induction motor</p> <p>Insulation Class: B Degree of Protection: IP68</p> <p>No. of Poles & Speed (Synchronous Speed) 4-pole, 1500/1800min⁻¹ (50/60Hz)</p> <p>Power Supply Voltages & Rated Currents</p> <table border="0"> <tr> <td>50Hz</td> <td>60Hz</td> </tr> <tr> <td>380V – 23.0A</td> <td>220V – 39.0A</td> </tr> <tr> <td>400V – 22.0A</td> <td>380V – 22.0A</td> </tr> <tr> <td>415V – 21.5A</td> <td>440V – 19.5A</td> </tr> </table> <p>Power Cable Sheath: Chloroprene rubber Standard Length: 8m 380 to 600V supply: 1 x 4 x 5.5mm², O.D. 19.8mm 200 to 240V supply: 1 x 4 x 8.0mm², O.D. 21.7mm</p> <p>Dry Weight (excluding cable) Free Standing Type: 196kg Guide Rail Fitting Type: 193kg</p>	50Hz	60Hz	380V – 23.0A	220V – 39.0A	400V – 22.0A	380V – 22.0A	415V – 21.5A	440V – 19.5A	<p>Impeller Semi-open Impeller made of high-chromium cast iron</p> <p>Solids Passage 50Hz – ϕ20mm 60Hz – ϕ20mm</p> <p>Agitator Ductile cast iron</p> <p>Cable Entry with Anti-Wicking Block Watertight cable entry with strain-relief device. The anti-wicking block prevents water incursion due to capillary action should the power cable be damaged or the end submerged.</p> <p>Bearing Permanently lubricated, deep-groove, double-shielded C3 ball bearings</p> <p>Shaft 420 stainless steel</p> <p>Shaft Seal (Mechanical Seal) Furnished with a double-face mechanical seal located in oil chamber. Both upper and lower seal faces always run in a clean environment.</p> <p>Upper Seal Face: SiC + SiC Lower Seal Face: SiC + SiC</p> <p>Oil Seal (Lip Seal) Used as a "Dust Seal", it protects the mechanical seal from abrasive particles.</p> <p>OIL LIFTER (Patented) Equipped in oil chamber. It forcibly supplies lubricating oil to the mechanical seal and continues to supply the oil to the upper seal faces even if lubricant falls below the rated volume.</p> <p>Type of Lubricating Oil & Volume Turbine Oil (ISO VG32), 2500ml</p> <p>Motor Protection Device A circle thermal protector built in the motor housing. Directly cuts the motor circuit if excessive heat builds up or an overcurrent condition occurs in the motor.</p>
50Hz	60Hz								
380V – 23.0A	220V – 39.0A								
400V – 22.0A	380V – 22.0A								
415V – 21.5A	440V – 19.5A								
TSURUMI MANUFACTURING CO., LTD.									

NO. A-22036-1

PUMP PERFORMANCE CURVES

TYPE Submersible Slurry Pump	MODEL NKZ3-100H	FREQUENCY 50 Hz
---------------------------------	--------------------	--------------------

CUSTOMER'S NAME _____

EQUIPMENT TITLE _____ NO. _____

	STANDARD SPECIFICATIONS	REQUIRED SPECIFICATIONS
DISCHARGE BORE	100 mm	mm
TOTAL HEAD	25 m	m
CAPACITY	1.0 m ³ /min	m ³ /min
MOTOR OUTPUT	11 kW	kW
PHASE x VOLTAGE	3 φ x V	φ x V
CURRENT	A	A
POLES / REVOLUTION	4 P / S. S. 1500 min ⁻¹	P / min ⁻¹
STARTING METHOD	DIRECT ON LINE	
INSULATION CLASS	B	

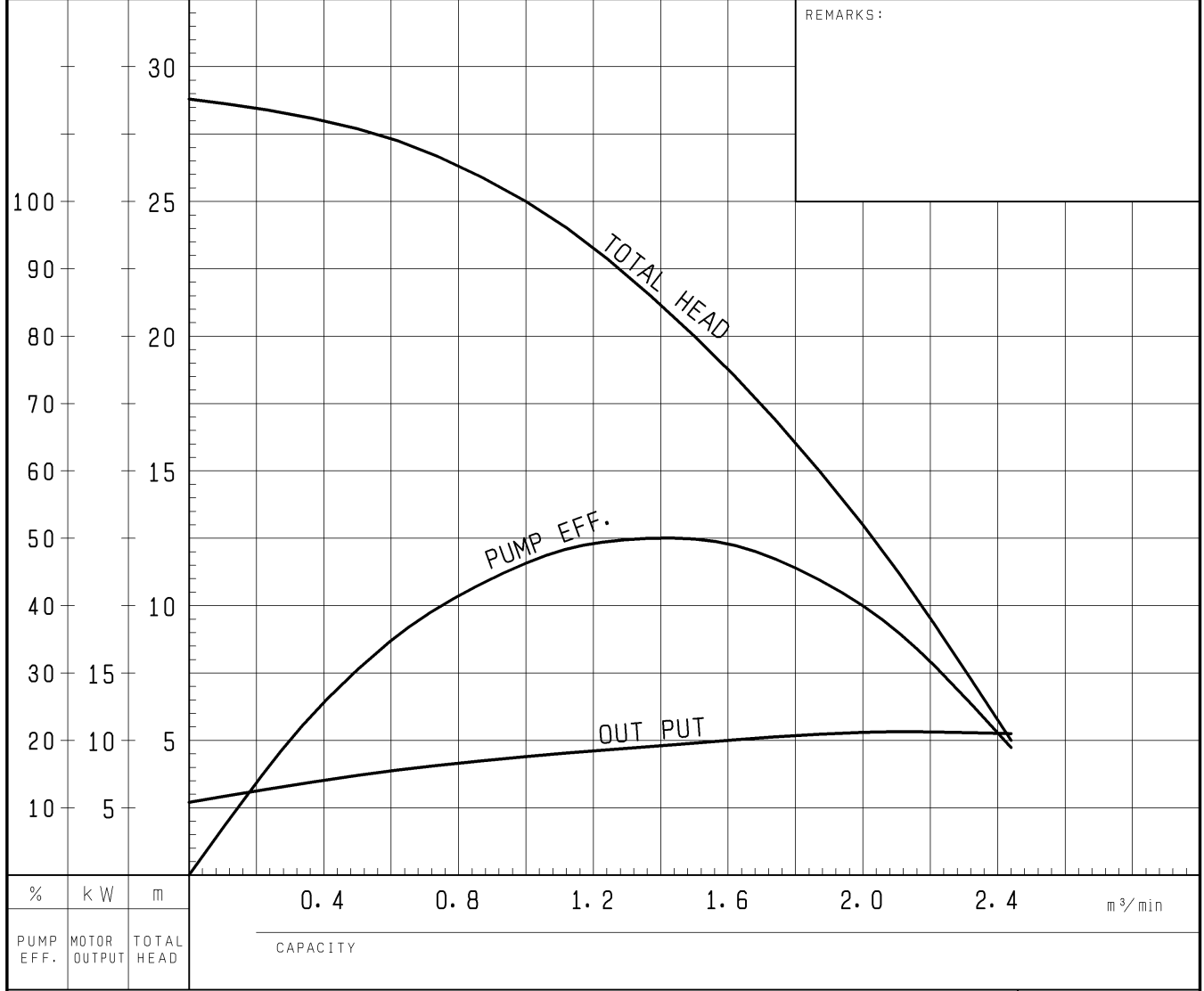

TSURUMI MFG. CO., LTD.

DIMENSION DRAWING		No.	No. A-22048-1
TYPE	Submersible Slurry Pump	MODEL	NKZ3-80H, NKZ3-100H

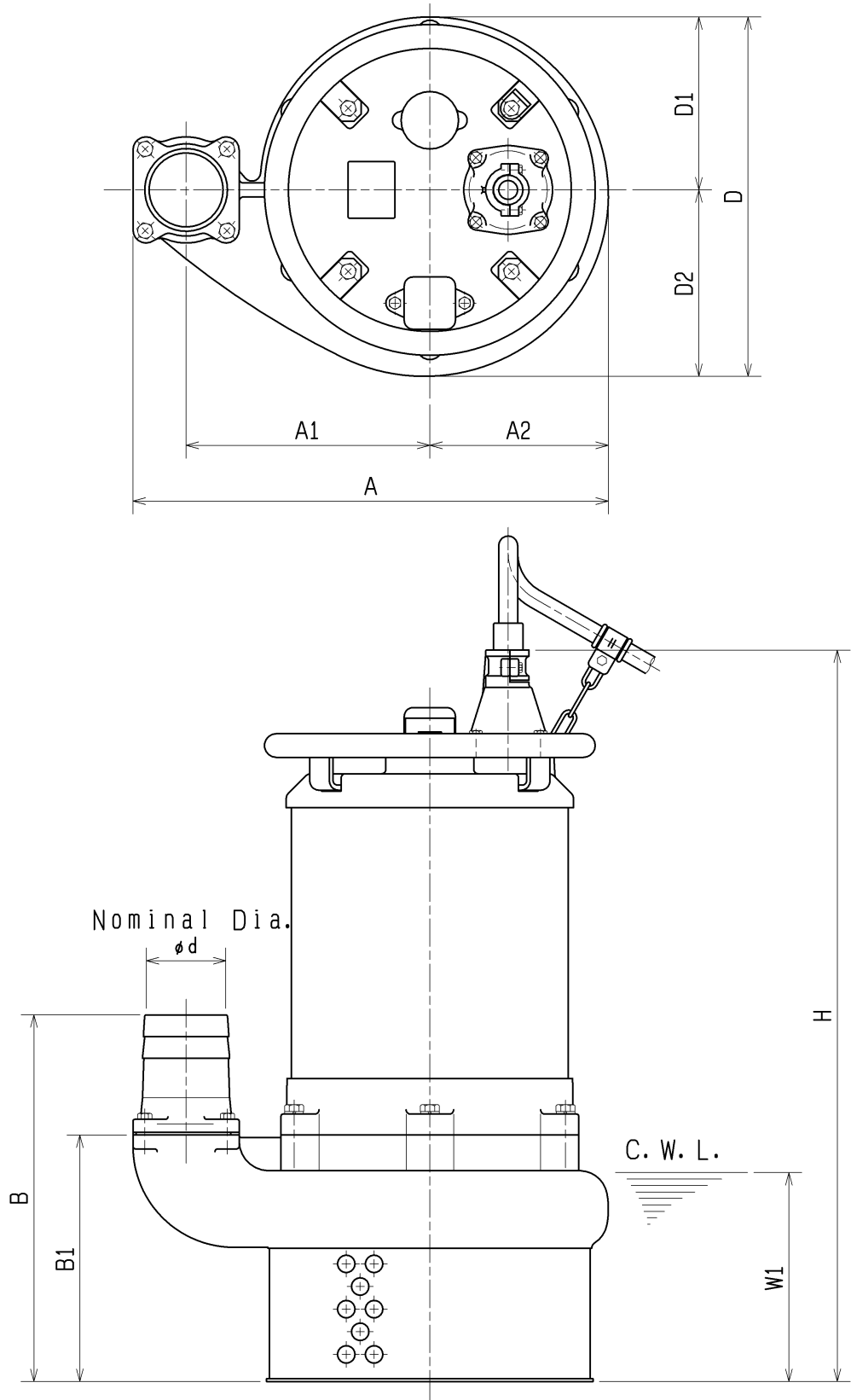

C. W. L. :Continuous running Water Level
 ※excluding cable

MODEL	ϕd	A	A1	A2	B	B1	D	D1	D2	W1	H	Approximate Weight (※)
NKZ3-80H	80	491	230	200	386	263	400	192	208	220	753	132kg
NKZ3-100H	100	546	280	205	421	283	413	199	214	240	840	196kg

SECTIONAL DRAWING		No.	No. A-22051-1
TYPE	Submersible Slurry Pump	MODEL	NKZ3-80H, NKZ3-100H

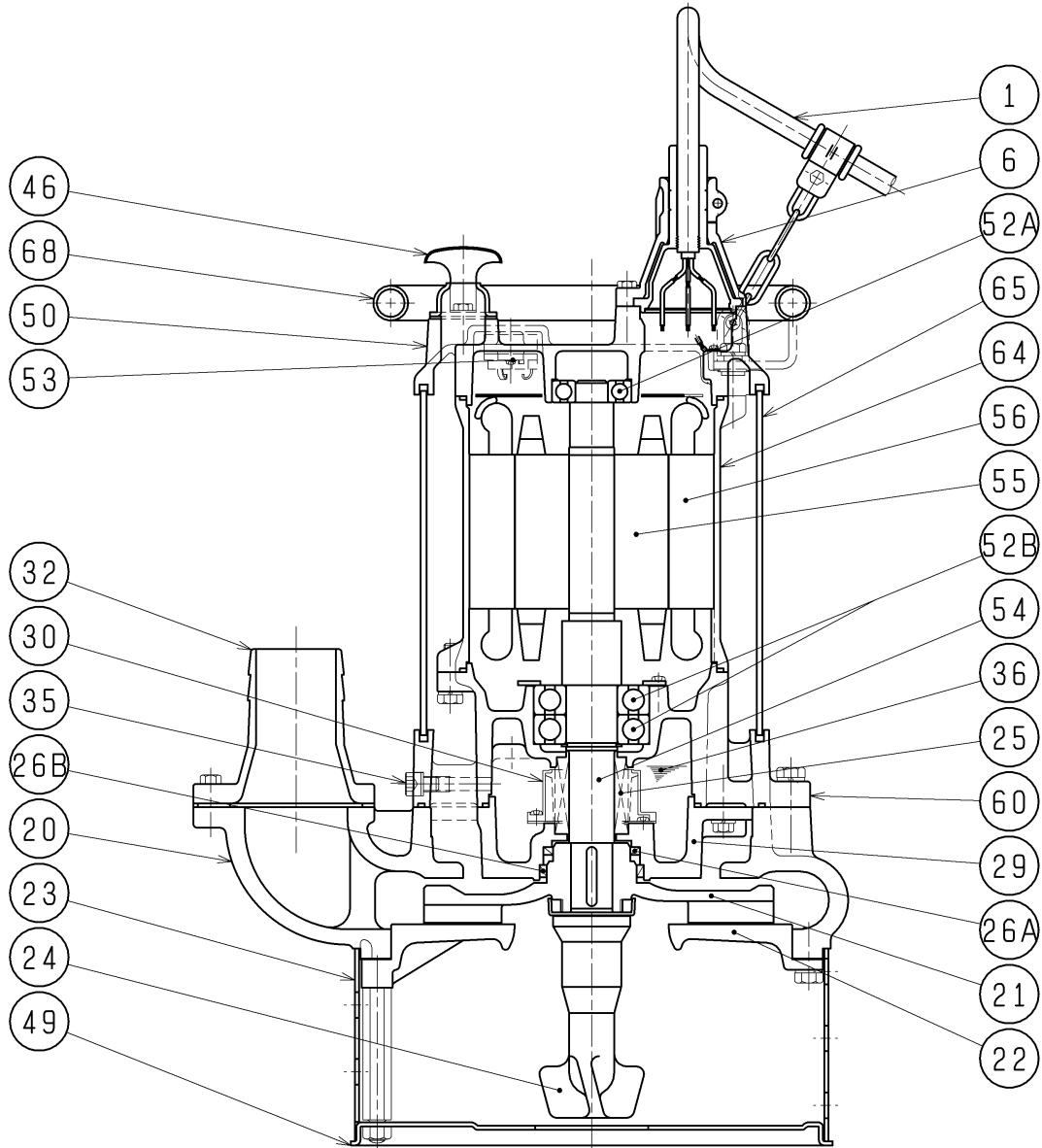

REQ. SPECIFICATION	

	※1	※2
5.5kW	6305ZZC3	6308ZZD2C3
11 kW	6307ZZC3	6310ZZD2C3

No.	DESCRIPTION	QTY	MATERIAL / NOTE	No.	DESCRIPTION	QTY	MATERIAL / NOTE
1	Cabtyre Cable	1	Chloroprene Sheath	46	Air Release Valve	1	Steel Sheet
6	Stuffing Box	1	Gray Iron Casting	49	Bottom Plate	1	Steel Sheet
20	Pump Casing	1	Gray Iron Casting	50	Motor Bracket	1	Gray Iron Casting
21	Impeller	1	Chromium Iron Casting	52A	Upper Bearing	1	※1
22	Suction Cover	1	Ductile Iron Casting(Quenching)	52B	Lower Bearing	1	※2
23	Strainer	1	Steel Sheet	53	Motor Protector	1	
24	Agitator	1	Ductile Iron Casting	54	Shaft	1	Stainless Steel 420J2
25	Mechanical Seal	1	H-35	55	Rotor	1	
26A	Oil Seal	1	VC60756	56	Stator	1	
26B	Oil Seal	1	TC71819.5	60	Bearing Housing	1	Gray Iron Casting
29	Oil Casing	1	Gray Iron Casting	64	Motor Frame	1	Gray Iron Casting
30	Oil Lifter	1	Plastic	65	Outer Cover	1	Steel Sheet
32	Hose Coupling	1	Gray Iron Casting	68	Handle	1	Steel Sheet & Carbon Steel Pipe
35	Oil Plug	1	Stainless Steel 304				
36	Lubricant		Turbine Oil (ISO VG32)				