

SERIES
KRS
KRD

SUBMERSIBLE
DEWATERING PUMPS





Submersible General-Purpose Dewatering Pumps

Tsurumi's KRS/KRD-series of submersible heavy-duty pumps are designed and built to handle high volume pumping jobs. The series offers three types of pumps: a basic (standard) type that is available in a wide product lineup, an energy-saving type of low output and low head that reduces power consumption, and a slurry dewatering type that is equipped with a high-chromium cast iron impeller and agitator.

Also offered are KRSU-series submersible pumps for bypassing sewage in sewer renewal work, which optionally come in a flange connection type for countermeasures to floods. Furthermore, after many years of research and application, Tsurumi has an optional seawater-resistant version that can draw and drain seawater over extended periods of time. All in all, KRS/KRD-series pumps are of multiple-purpose build and widely applicable.

KRS/KRD-series pumps are available in a broad product lineup with discharge bore diameters of 80 to 250 mm, and motor outputs of 2.2 to 22 kW. All models integrate original technologies that Tsurumi has over the years researched and proven in the field, including Tsurumi's original anti-wicking cable, dual inside mechanical seals with silicon carbide faces and Oil Lifter, etc.

Tsurumi pumps have and continue to play an active role in a wide range of applications, covering civil engineering and construction work that requires high reliability, large-scale construction projects such as tunnels, bridges and dams, and infrastructure for provisional drainage of sewage, simplified rainwater drainage for flood countermeasures, etc.



KRS
Drainage Pumps



KRS
(Energy-Saving)
Energy-saving Drainage Pumps



KRD
KRS(Slurry)
Slurry Pumps



KRSU
Submersible Pump for
Sewage Bypass



KRS: Multi-purpose drainage pumps available in a wide product lineup

KRS (Energy-Saving): Drainage pumps of low output and low head that reduce power consumption

KRD / KRS (Slurry) : Slurry pumps that deliver powerful agitation for discharging slurries laden with silt, earth, sand or other particulate

KRSU: Submersible pump for provisional sewage bypass between manholes

Selection Table

Motor Output		2.2-3.7 kW	5.5 kW	7.5 kW	9-11 kW	15-18.5 kW	22 kW
KRS	3" 80mm						
	4" 100mm						
	6" 150mm						
	8" 200mm						
	10" 250mm						
KRS -Energy-Saving-	4" 100mm						
	6" 150mm						
	8" 200mm						
KRD KRS -Slurry-	3" 80mm						
	4" 100mm						
	6" 150mm						
	8" 200mm						
KRSU	6" 150mm						

Flange Connection Type Pump for Flood Countermeasures

Tsurumi offers pumps of flange connection type as countermeasures to river flooding and submerged roads caused by large-scale natural disasters (hurricanes, squalls, local downpours, etc.), which have occurred more frequently in recent years.

By using the flange connection type, the KRS/KRD-series pumps can also serve as simplified rainwater drainage pumps. Since the flange connection type can be easily installed and removed, and features the sound reliability, durability and maintainability demanded of construction work, the pump can make a contribution as a countermeasure to floods.



Options

Seawater-Resistant Version

Tsurumi's pumps can be combined with a seawater-resistant kit (optional) that adds a "galvanic anode" and "seawater-resistant special cast iron impeller," and enables about two years of service. (The service period depends on operating conditions.) For details, refer to the Seawater-Resistant Pumps catalog [IB115].



High Temperature Liquids Version

Tsurumi's pumps are applicable to high temperature liquids of up to 80°C. Pumps of the standard specification can discharge liquids of up to 40°C. However, there are many fields that need to discharge higher temperature liquids, e.g., discharging industrial water from a power plant or ironworks, or discharging hot spring water from a mine in a volcanic zone.

High Voltage Version

Tsurumi's pumps can be manufactured to between 380 - 1000V ratings that are often required for mining applications. The pumps meet mining safety standards as they come with screened cables and motors with built-in diodes for ground-fault checks.



Top Discharge, Side Flow Design

This design assures efficient motor cooling even if the pump runs with its motor exposed to air, and also allows the overall diameter of the pump to be reduced for installation in confined spaces.

* Model KRS1022 is a top discharge, flow-thru design. It provides maximum motor cooling efficiency allowing continuous operation at low water levels and extended dry-run capability.

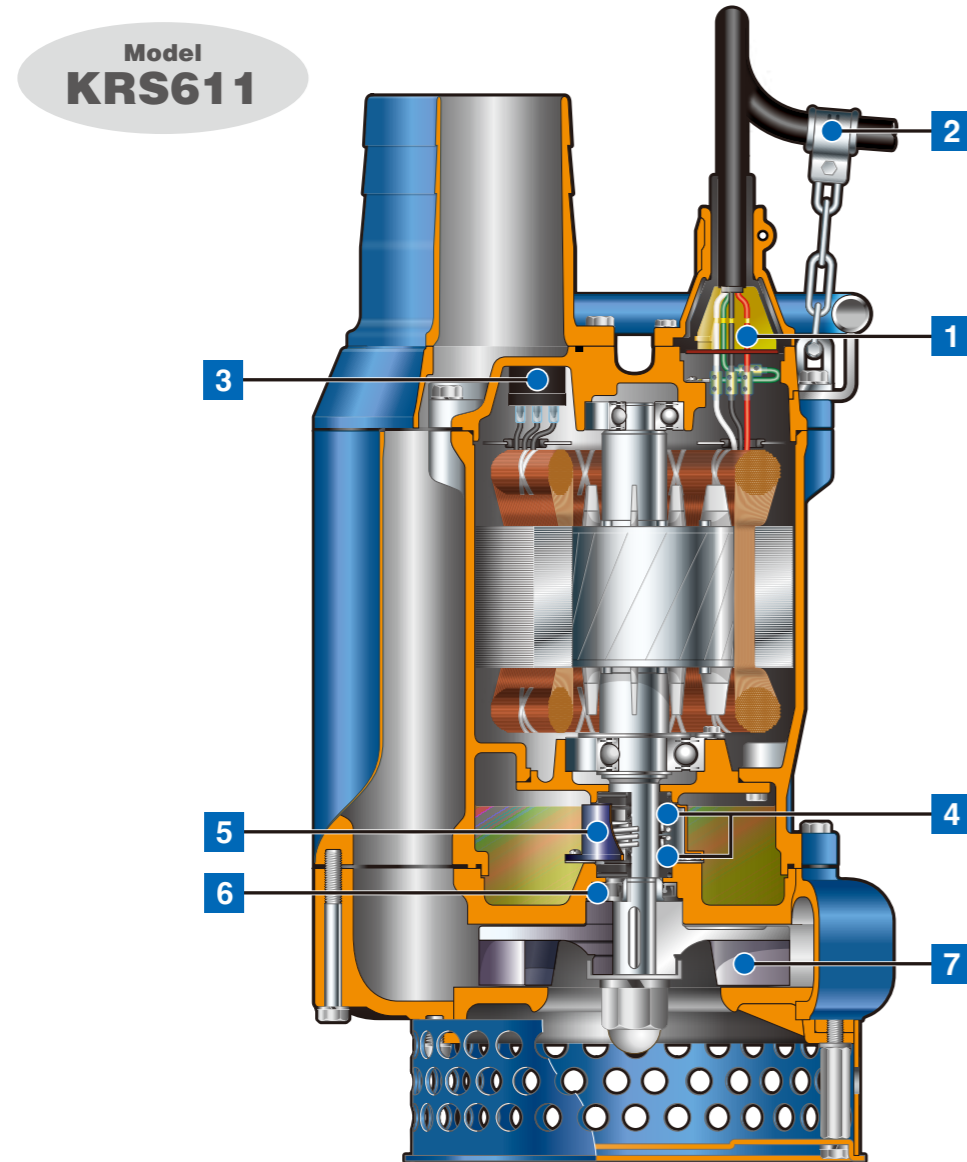

1 Anti-wicking Cable Entry

Prevents water incursion due to capillary action should the cable sheath be damaged or the end of cable submerged. Also prevents moist air from infiltrating the motor housing and condensation from forming inside the housing due to temperature differences between the housing and outside air.

2 Cable Clip

Prevents unexpected water incursion that can occur if the cable is damaged, by protecting the cable against the tugging and rough handling found at construction sites.

3 Circle Thermal Protector

Directly cuts the motor circuit if excessive heat builds up or overcurrent occurs in the motor.

4 Dual Inside Mechanical Seals with Silicon Carbide Faces

Isolated in the oil chamber where a clean, non-corrosive and abrasion-free lubricating environment is maintained. Compared with the water-cooled outside mechanical seal, it reduces the risk of failure caused by dry-heating and adhering matter. The silicon carbide provides 5 times higher corrosion, wear and heat resistance than the tungsten carbide. Rubber parts of the upper and lower fixing rings are made of NBR or FPM (FKM), which provides higher resistance to heat and chemicals.

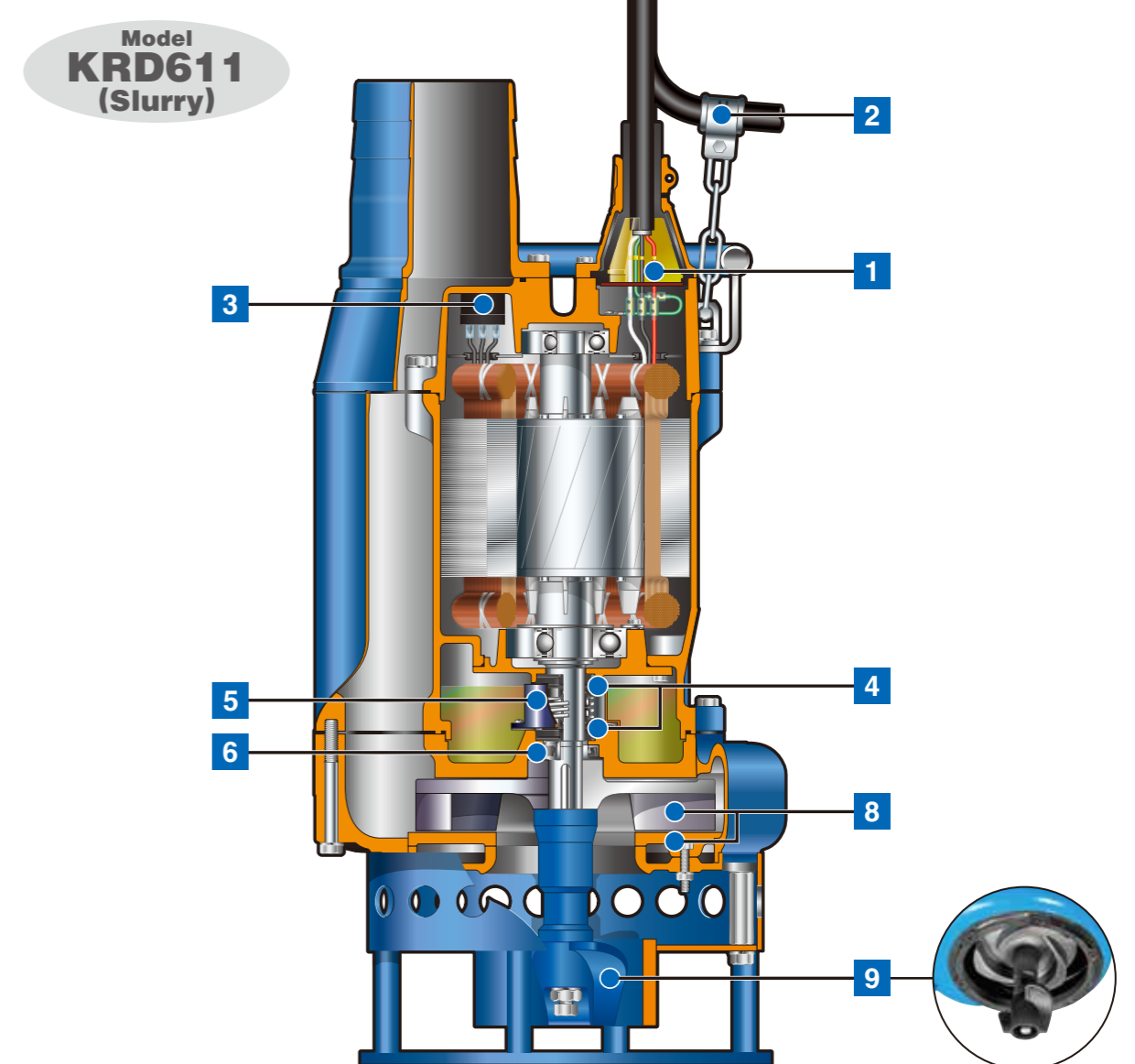

5 Oil Lifter

Provides lubrication and cooling of the seal faces down to 1/3 of normal oil level, thus maintaining a stable shaft sealing effect and prolonging seal life longer. The Oil Lifter is Tsurumi original design.

6 Oil Seal

Used as a "Dust Seal", it protects the mechanical seal from abrasive particles.

7 Ductile Cast Iron Semi-open Impeller (KRS & KRS-Energy-Saving-) / Ductile Cast Iron Semi-vortex Impeller (KRSU)

Resists wear caused by abrasive particles and enables the pump to maintain its original performance for an extended period of time.

8 High-chromium Cast Iron Semi-open Impeller & Suction Plate (KRD & KRS-Slurry-)

Made of high-chromium cast iron ensuring highest durability. Even if the performance drops due to wearing out of the impeller and/or suction plate, it can be improved by simply replacing the suction plate.
* KRS-200 has an adjustable suction plate

9 Agitating Mechanism (KRD & KRS-Slurry-)

Consists of a shaft-mounted agitator and a dedicated strainer. The agitator made of high-chromium cast iron resists wear caused by abrasive particles, and it suspends solids to assist in pumping sediments in combination with the strainer.

Multi-purpose drainage pumps available in a wide product lineup

The KRS-series is a submersible three-phase cast iron high volume heavy-duty drainage pump. The cast iron body, combined with the low speed motor, presents extra durability for use in the most demanding conditions. The top discharge, side flow design assures efficient motor cooling even when it operates with its motor exposed to air.*

* Model KRS1022 is a top discharge, flow-thru design. It provides maximum motor cooling efficiency allowing continuous operation at low water levels and extended dry-run capability.



KRS811

KRS1022

Discharge Bore mm	Model	Motor Output kW	Phase	Starting Method	Solids Passage mm	Dimensions L x W x H 50/60Hz mm	Dry Weight* ² 50/60Hz kg	Cable Length m
80	KRS32.2	2.2	Three	D.O.L.* ¹	12	340 x 311 x 622	72	8
80	KRS33.7	3.7		D.O.L.* ¹	12	362 x 346 x 707/ 349 x 320 x 707	91/89	8
100	KRS43.7	3.7		D.O.L.* ¹	12	349 x 320 x 722	88	8
100	KRS45.5	5.5		D.O.L.* ¹	12	364 x 346 x 747	100/97	8
150	KRS67.5	7.5		D.O.L.* ¹	20	418 x 379 x 866	141	8
150	KRS611	11		D.O.L.* ¹	20	436 x 407 x 875/ 418 x 379 x 873	163/155	8
200	KRS811	11		D.O.L.* ¹	30	473 x 409 x 993	179	8
200	KRS815	15		D.O.L.* ¹	25	481 x 440 x 1069	240	8
200	KRS819	18.5		D.O.L.* ¹	25	576 x 530 x 1241	360	10
200	KRS822	22		D.O.L.* ¹	25	576 x 530 x 1241	380	10
200	KRS822L	22	D.O.L.* ¹	25	576 x 530 x 1241	380	10	
250	KRS1022	22	D.O.L.* ¹	25	525 x 524 x 1419	390	10	

*¹ Star-Delta available upon request

*² Weights excluding cable

Performance Curves

< 80-150mm >

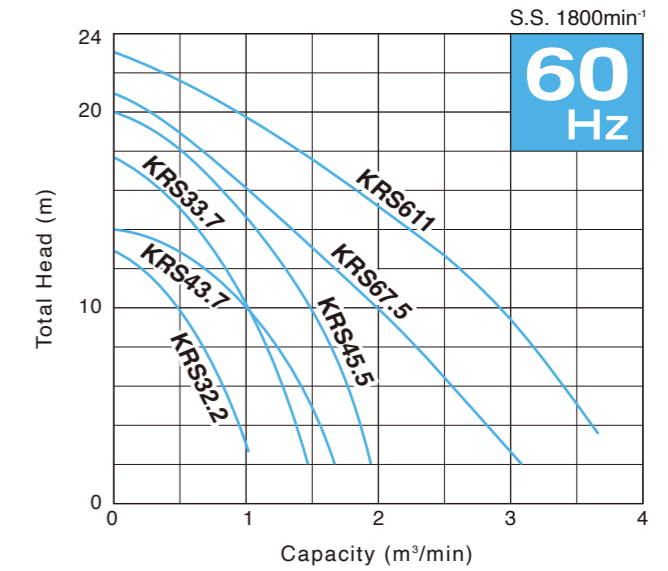
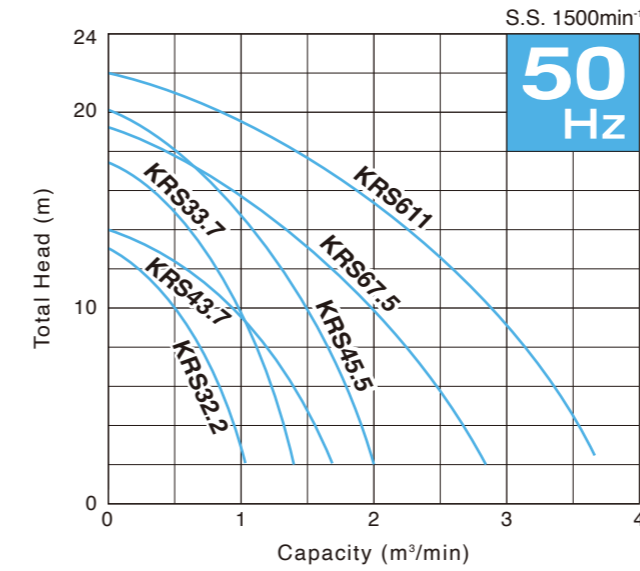

< 200 · 250mm >

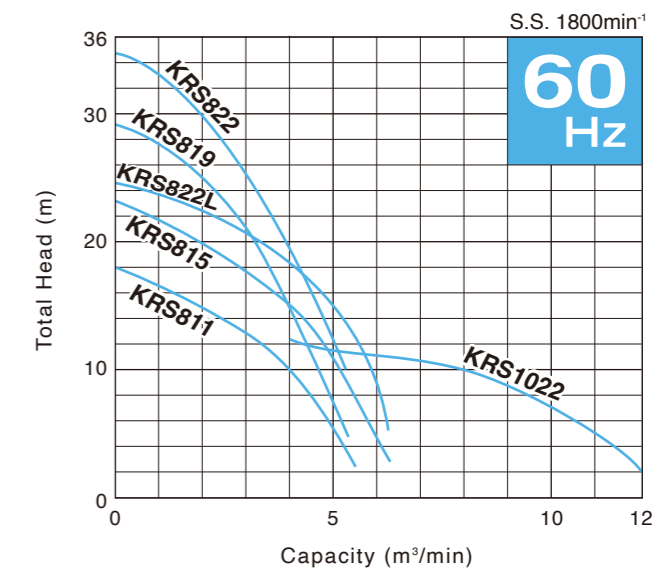
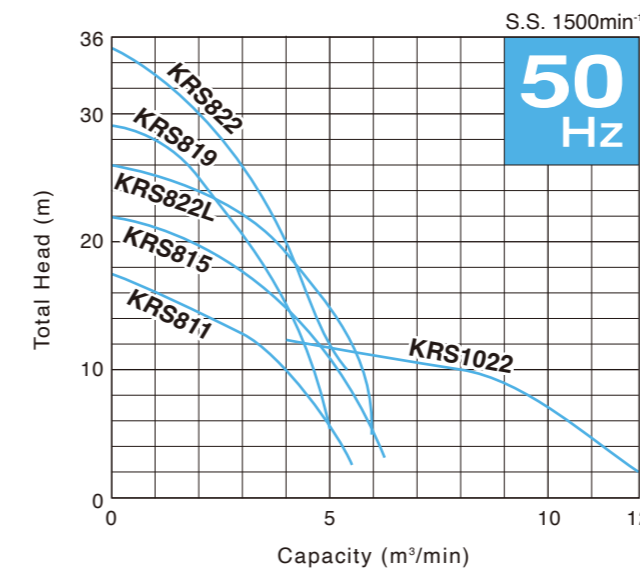

KRS (Energy-Saving)

Drainage pumps of low output and low head that reduce power consumption

The KRS-series of energy-saving type is a submersible three-phase cast iron high volume heavy-duty drainage pump. It consumes less energy than the standard KRS-series at lower head applications. The cast iron body, combined with the low speed motor, presents extra durability for use in the most demanding conditions. The top discharge, side flow design assures efficient motor cooling even when it operates with its motor exposed to air.



KRS2-69



KRS2-89

Performance Curves

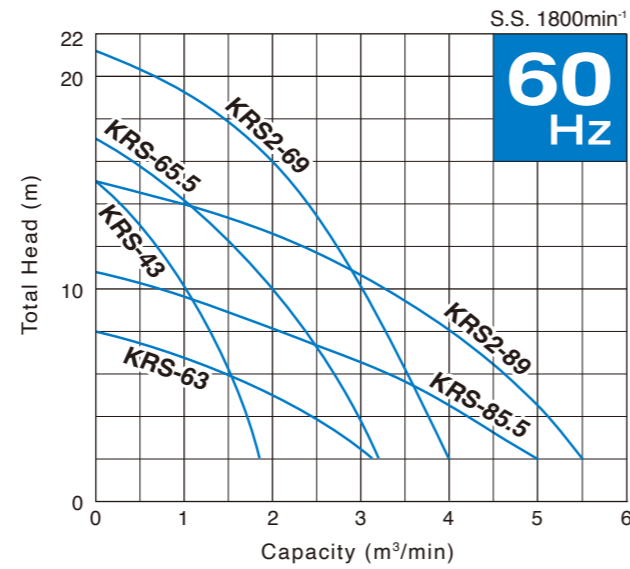
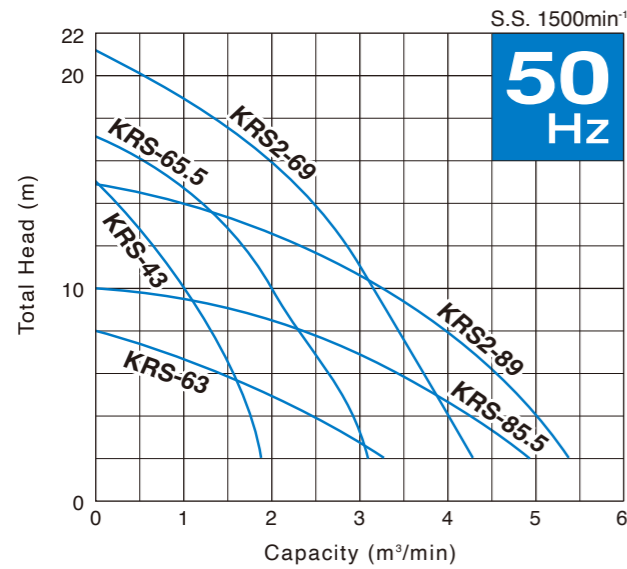

Discharge Bore mm	Model	Motor Output kW	Phase	Starting Method	Solids Passage mm	Dimensions L x W x H mm	Dry Weight* ² kg	Cable Length m
100	KRS-43	3	Three	D.O.L.* ¹	12	378 x 347 x 723	95	8
150	KRS-63	3		D.O.L.* ¹	15	384 x 365 x 866	97	8
150	KRS-65.5	5.5		D.O.L.* ¹	20	425 x 370 x 790	118	8
150	KRS2-69	9		D.O.L.* ¹	20	490 x 424 x 812	155	8
200	KRS-85.5	5.5		D.O.L.* ¹	20	446 x 413 x 941	126	8
200	KRS2-89	9		D.O.L.* ¹	30	473 x 408 x 933	175	8

*¹ Star-Delta available upon request

*² Weights excluding cable

KRD/KRS (Slurry)

Slurry pumps that deliver powerful agitation for discharging slurries laden with silt, earth, sand or other particulate

The KRD/KRS-series of slurry-handling type is a submersible three-phase cast iron heavy-duty slurry pump. It is equipped with a high-chromium cast iron agitator that assists smooth suction of the settled matters. The other wear parts such as the impeller and the suction plate are also made of high-chromium cast iron for extra durability. The top discharge, side flow design assures efficient motor cooling even when it operates with its motor exposed to air.



KRD35.5



KRD611

Performance Curves

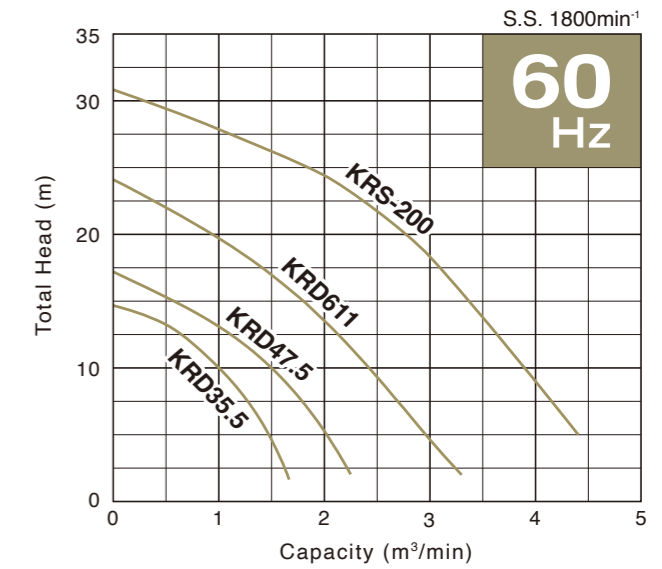
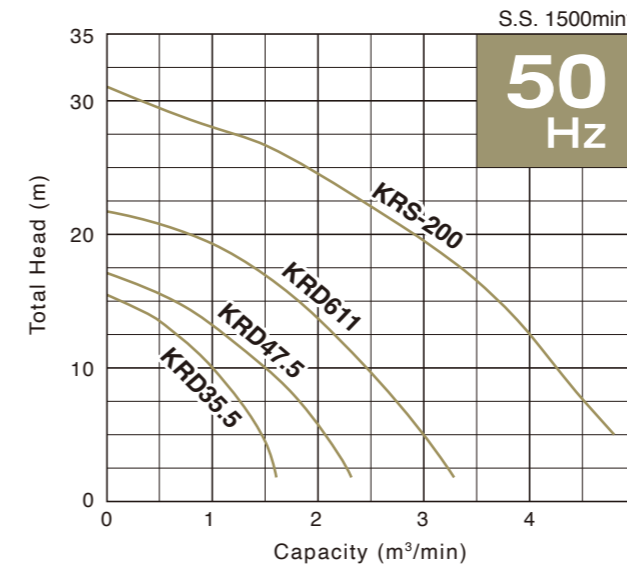

Discharge Bore mm	Model	Motor Output kW	Phase	Starting Method	Solids Passage mm	Dimensions L x W x H mm	Dry Weight* ² 50/60Hz kg	Cable Length m
80	KRD35.5	5.5	Three	D.O.L.* ¹	30	351 x 326 x 838	107	8
100	KRD47.5	7.5		D.O.L.* ¹	30	418 x 379 x 936	154	8
150	KRD611	11		D.O.L.* ¹	30	436 x 407 x 961	175/167	8
200	KRS-200	18		D.O.L.* ¹	30	576 x 530 x 1140	395	10

*¹ Star-Delta available upon request

*² Weights excluding cable

Submersible pump for provisional sewage bypass between manholes

The KRSU822 pump of submersible three-phase cast iron heavy-duty pump is designed and built specifically for temporarily bypassing drainage in sewer construction work. With a maximum head of 26.5 m, maximum capacity of 5.7 m³/min, and space-saving design of 546 mm in diameter, this pump plays an active role in drainage in the deep confined space of a manhole.

Also, with its semi-vortex structure, this pump provides a large solids passage of 56 mm in diameter, which prevents any clogging of solids matter. The top discharge, side flow design assures efficient motor cooling even when operating with the motor exposed to air.



KRSU822

Performance Curves

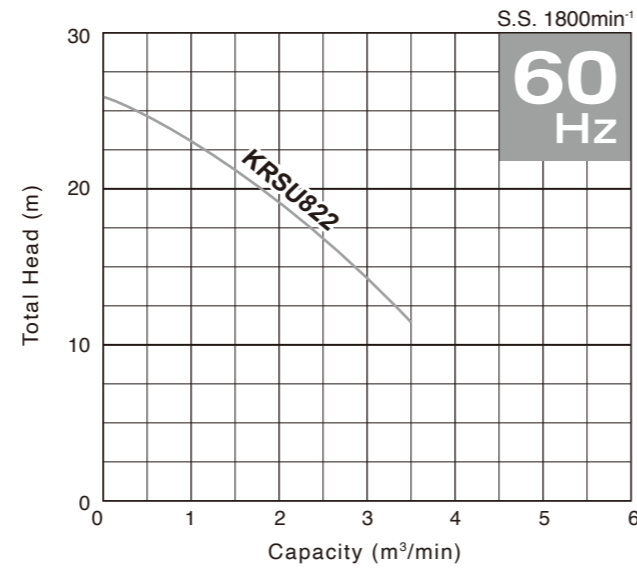
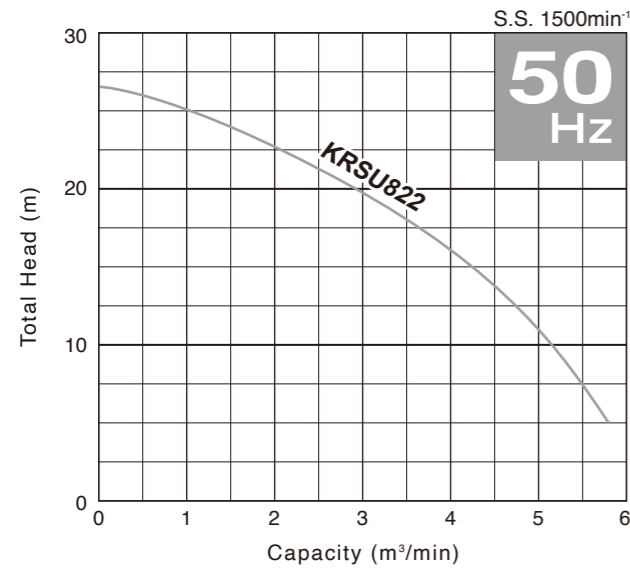

Discharge Bore mm	Model	Motor Output kW	Phase	Starting Method	Solids Passage mm	Dimensions L x W x H mm	Dry Weight* ² kg	Cable Length m
200	KRSU822	22	Three	D.O.L.* ¹	56	546 x 500 x 1486	430	10

*¹ Star-Delta available upon request

*² Weights excluding cable

Submersible Sewer Bypass Pumping

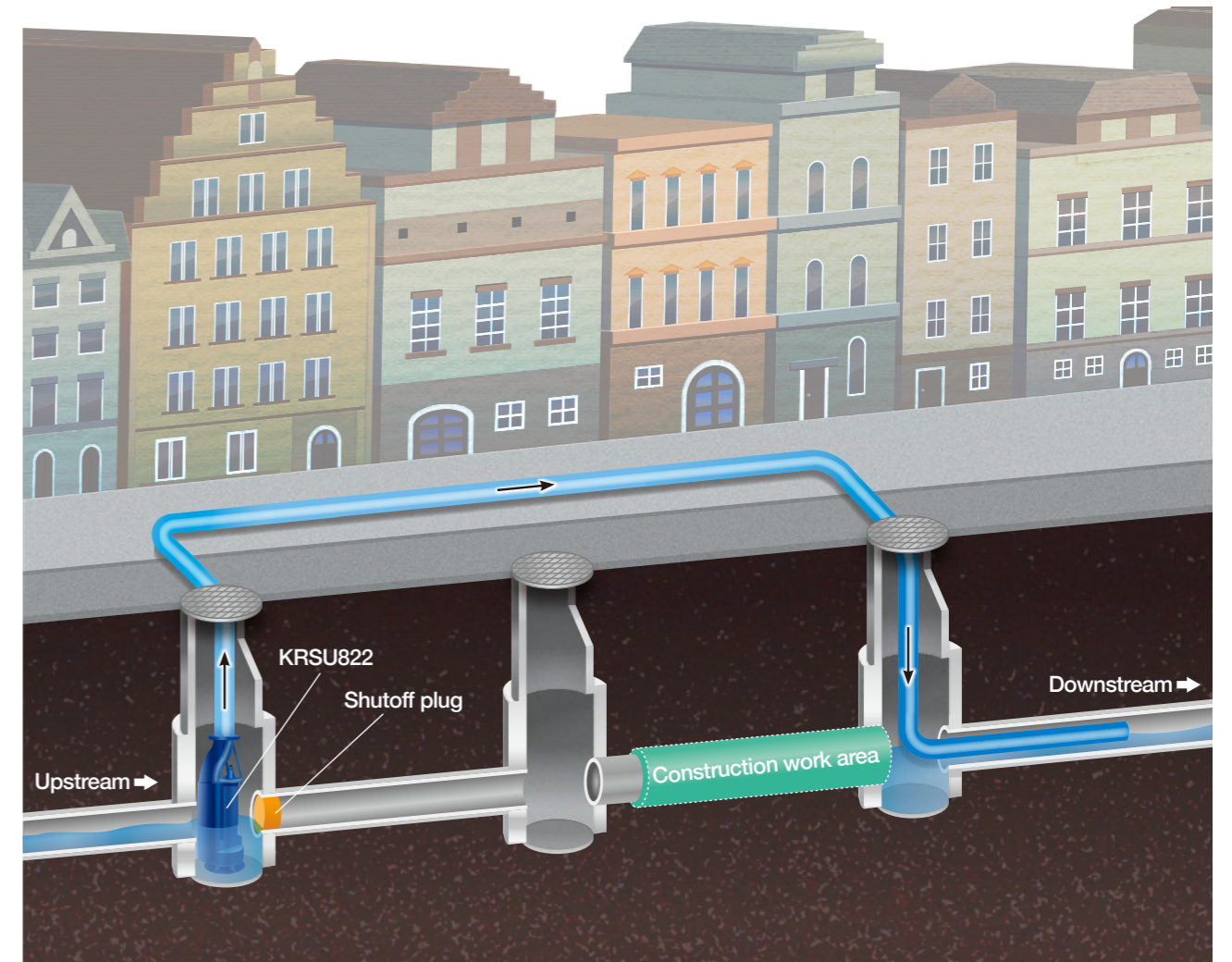

Since sewage piping suffers from aging-related deterioration and can be damaged by earthquakes, sewage piping requires repairs and replacing at regular intervals. In sewage piping repair work, consideration should be given to area residents inconvenienced by the repair work, and additionally to work efficiency and the safety and health of workers who handle inflow sewage. For this purpose, provisional draining that temporarily bypasses sewage via a pump is extremely effective.

As a pump for bypassing sewage between manholes in sewer piping renewal work, Tsurumi offers the KRSU822 pump of submersible sewer bypass pump. This pump features a maximum head of 26.5 m, a maximum capacity of 5.7 m³/min, and a compact space-saving design of just 546 mm in diameter. Normally, with engine pumps, it is difficult to suck up fluid from a depth of 7 m or more, but the KRSU submersible pump can fit in the deep limited confines of a manhole and there play an active role in draining the manhole. In addition, with its semi-vortex structure, this pump provides a large solids passage of 56 mm in diameter, which prevents clogging of solids matter. In fact, it is particularly effective towards preventing clogging of fibrous solids in the impeller, which is the biggest problem in draining sewage. The stand has a bottom plate structure so that the pump can stably stand by itself even when the pump is placed on earth, sand or sludge. The KRSU822 has a top discharge, side flow structure that effectively cools the motor even when the pump runs with the motor exposed to air. Thus, the KRSU822 is highly suited as a bypass pump.

Specifications

		KRS											KRS	KRS (Energy-Saving)						KRD/KRS (Slurry)				KRSU		
		KRS 32.2	KRS 33.7	KRS 43.7	KRS 45.5	KRS 67.5	KRS 611	KRS 811	KRS 815	KRS 819	KRS 822	KRS 822L		KRS 1022	KRS -43	KRS -63	KRS -65.5	KRS 2-69	KRS -85.5	KRS 2-89	KRD 35.5	KRD 47.5	KRD 611	KRS -200	KRSU 822	
PUMP	Discharge Bore mm	80		100		150		200						250	100	150			200			80	100	150	200	
	Discharge Connection	Hose Coupling											Hose Coupling										JIS 10kg/cm ² Flange			
	Solids Passage mm	12			20		30		25					25	12	15	20			30					56	
	Impeller	Semi-open											Closed	Semi-open										Semi-vortex		
		Ductile Cast Iron											Ductile Cast Iron					High-chromium Cast Iron					Gray Cast Iron			
	Suction Cover	Gray Cast Iron											Gray Cast Iron													
	Suction Plate	—											—					High-chromium Cast Iron					—			
	Oil Seal	Nitrile Butadiene Rubber											Nitrile Butadiene Rubber													
	Casing	Gray Cast Iron											Gray Cast Iron													
	Shaft Seal	Dual Inside Mechanical Seals (with Oil Lifter)											Dual Inside Mechanical Seals (with Oil Lifter)													
Silicon Carbide											Silicon Carbide															
Agitator	—											—					High-chromium Cast Iron					—				
MOTOR	Type	Continuous-duty Rated, Dry-type Induction Motor											Continuous-duty Rated, Dry-type Induction Motor													
	Output kW	2.2	3.7	5.5	7.5	11	15	18.5	22				22	3	5.5	9	5.5	9	5.5	7.5	11	18	22			
	Phase	Three											Three													
	Pole	4											4													
	Insulation	F											F	E			B	E	B	F						
	Starting Method	D.O.L.* ²											D.O.L.* ²													
	Motor Protector (built-in)	CTP											CTP													
	Lubricant ml	1200	1850			2300		3200	6500					4000	1440		1960	2300	1960	2300	1850	2300		6500		
		Turbine Oil (ISO VG32)											Turbine Oil (ISO VG32)													
	Frame	Gray Cast Iron											Gray Cast Iron													
Shaft	420 Stainless Steel											420 Stainless Steel														
Power Cable m	8					10						10	8					10								
	Chloroprene Rubber											Chloroprene Rubber														
Dry Weight* ¹ 50/60Hz kg	72	91/89	88	100/97	141	163/155	179	240	360	380			390	95	97	118	155	126	175	107	154	175/167		395	430	

*¹ Weights excluding cable
*² Star-Delta available upon request



We reserve the right to change the specifications and designs without prior notice. The OO series and model OO are indicated with our series/model codes in this catalog.

**TSURUMI
MANUFACTURING CO., LTD.**

Your Dealer