

FHP Series

Floating Decanter

OPERATION MANUAL

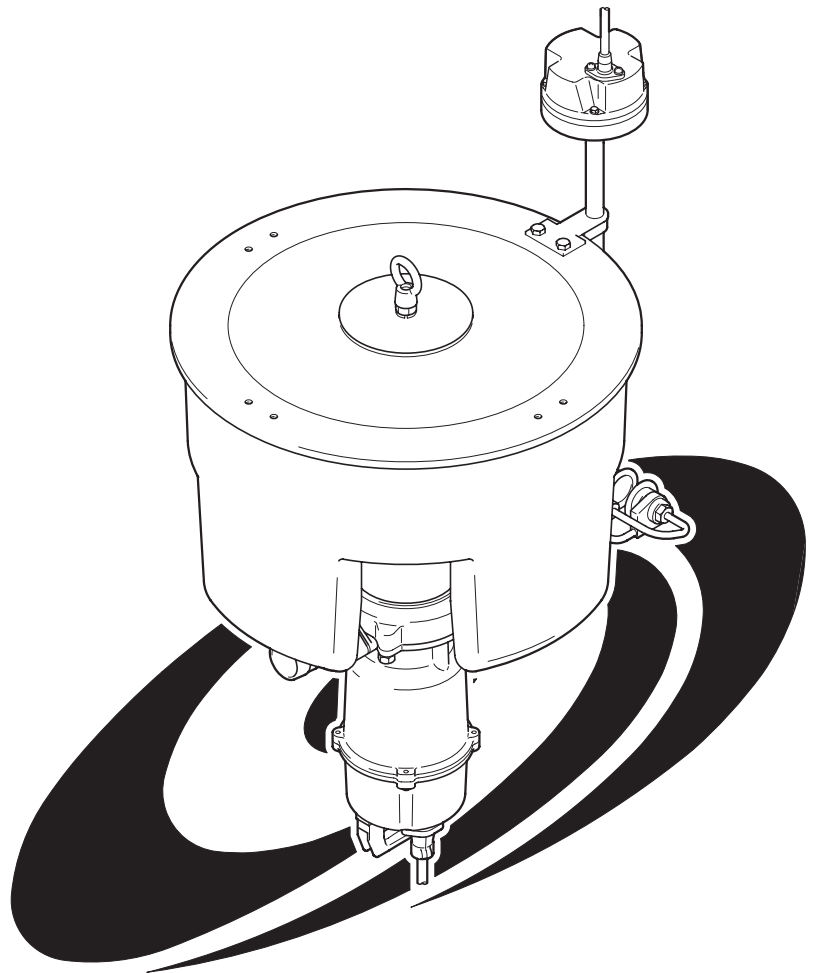

TSURUMI MANUFACTURING CO., LTD.

INTRODUCTION

Thank you for selecting the Tsurumi FHP Series floating decanter.

This operation manual explains the product operations and gives important precautions regarding its safe use. In order to use the product to maximum benefit, be sure to read the instructions thoroughly and follow them carefully.

To avoid accident, do not use the product in any way other than as described in this operation manual. Note that the manufacturer cannot be responsible for accidents arising because the product was not used as prescribed. After reading this operation manual, keep it nearby as a reference in case questions arise during use.

When lending this product to another party, always be sure to include this operation manual as well.

If this operation manual should become lost or damaged, ask your nearest dealer or Tsurumi representative for another copy.

Every effort has been made to ensure the completeness and accuracy of this document. Please contact your nearest dealer or Tsurumi representative if you notice any possible error or omission.

The contents of this document may not be copied in whole or in part without the express permission of Tsurumi Manufacturing Co., Ltd.

CONTENTS

1. BE SURE TO READ FOR YOUR SAFETY	2
2. NAME OF PARTS	5
3. PRIOR TO OPERATION	5
4. INSTALLATION	7
5. ELECTRICAL WIRING	10
6. OPERATION.....	12
7. MAINTENANCE AND INSPECTION	14
8. DISASSEMBLY AND REASSEMBLY PROCEDURE	16
9. TROUBLESHOOTING	19

1 BE SURE TO READ FOR YOUR SAFETY

Be sure to thoroughly read and understand the SAFETY PRECAUTIONS given in this section before using the equipment in order to operate the equipment correctly.

The precautionary measures described in this section are intended to prevent danger or damage to you or to others. The contents of this manual that could possibly be performed improperly are classified into two categories: **⚠ WARNING**, and **⚠ CAUTION**. The categories indicate the extent of possible damage or the urgency of the precaution. Note however, that what is included under **⚠ CAUTION** may at times lead to a more serious problem. In either case, the categories pertain to safety-related items, and as such, must be observed carefully.

- **⚠ WARNING** : Operating the equipment improperly by failing to observe this precaution may possibly lead to death or injury to humans.
- **⚠ CAUTION** : Operating the equipment improperly by failing to observe this precaution may possibly cause injury to humans and other physical damage.
- **NOTE** : Gives information that does not fall in the WARNING or CAUTION categories.
- **Explanation of Symbols:**



: The \triangle mark indicates a WARNING or CAUTION item. The symbol inside the mark describes the precaution in more detail ("electrical shock", in the case of the example on the left).



: The \circ mark indicates a prohibited action. The symbol inside the mark, or a notation in the vicinity of the mark describes the precaution in more detail ("disassembly prohibited", in the case of the example on the left).



: The \bullet mark indicates an action that must be taken, or instructs how to perform a task. The symbol inside the mark describes the precaution in more detail ("provide ground work", in the case of the example on the left).

PRECAUTIONS TO THE PRODUCT SPECIFICATIONS

⚠ CAUTION













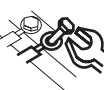
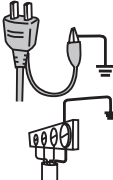









● Do not operate the product under any conditions other than those for which it is specified. **Failure to observe the precaution can lead to electrical leakage, electrical shock, fire, or other problems.**

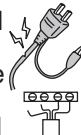







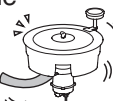









PRECAUTIONS DURING TRANSPORT AND INSTALLATION





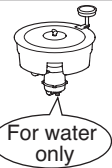

⚠ WARNING

	<p>● When transporting the product, pay close attention to its center of gravity and mass. Use an appropriate lifting equipment to lift the unit. Improper lifting may result in the product damage, injury, or death.</p> 		<p>● Install the product properly in accordance with this operation manual. Improper installation may result in electrical leakage, electrical shock, fire, or injury.</p> 
	<p>● Electrical wiring should be performed in accordance with all applicable regulations in your country. Absolutely provide a dedicated earth leakage circuit breaker and a thermal overload relay suitable for the pump (available on the market). Imperfect wiring or improper protective equipment can lead to electrical leakage, fire, or explosion in the worst case.</p> 		<p>● Provide a secure grounding dedicated for the product. Never fail to provide an earth leakage circuit breaker and a thermal overload relay in your starter or control panel (Both available on the market). If an electrical leakage occurs by due to a product failure, it may cause electrical shock.</p> 
	<p>● Use a power outlet that has a sufficient rating and has been exclusively provided for the pump. If the power outlet is shared with other equipment, it can lead to an abnormal heat of the outlet and can cause fire as a result.</p>		<p>Power Supply Capacity </p>









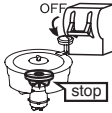

 CAUTION			
	<ul style="list-style-type: none"> ● Be sure to provide a ground wire securely. Do not connect the ground wire to a gas pipe, water pipe, lightning rod, or telephone ground wire. Improper grounding could cause electrical shock. 		<ul style="list-style-type: none"> ● Prevent a metallic object or dust from sticking to the power plug. Adhesion of foreign object to the plug could cause electrical shock, short-circuit, or fire. 
	<ul style="list-style-type: none"> ● Do not scratch, fold, twist, make alterations, or bundle the cable, or use it as a lifting device. The cable may be damaged, which may cause electrical leakage, short-circuit, electrical shock, or fire. 		<ul style="list-style-type: none"> ● Do not use the cable, power plug, or power outlet if it is damaged or it is not closely fitted. Connect every conductor of the cable securely to the terminals. Failure to observe this can lead to electrical shock, short-circuit, or fire. 
	<ul style="list-style-type: none"> ● Install the discharge pipe securely so that no water leakage may occur. In addition, It is suggested to provide a stand-by pump in case of flooding. Failure to do so may result in damage to nearby walls, floors, and other equipment. 		<ul style="list-style-type: none"> ● When the product will be carried by hand, decide the number of persons considering the mass of the product. When lifting up the product, do not attempt to do it by simply bowing from the waist. Use the knees, too, to protect your waist. 
	<ul style="list-style-type: none"> ● This pump is neither dust-proof nor explosion-proof. Do not use it at a dusty place or at a place where toxic, corrosive or explosive gas is present. Use in such places could cause fire or explosion. 		<ul style="list-style-type: none"> ● If a hose is used for the discharge line, take a measure to prevent the hose from shaking. If the hose shakes, you may be wet or injured. 

PRECAUTIONS DURING TEST OPERATION AND OPERATION

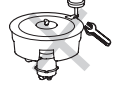

 WARNING			
	<ul style="list-style-type: none"> ● Never try to operate the pump if somebody is present in the pump sump. If an electrical leakage occurs, it can cause electrical shock. 		<ul style="list-style-type: none"> ● Never start the pump while it is suspended, as the unit may jerk and could lead to injury. 
	<ul style="list-style-type: none"> ● When changing power connection is needed to correct the direction of rotation, be sure to turn off the power supply (earth leakage circuit breaker, etc.), and perform the work after making sure that the impeller has stopped completely. Failure to do so may lead to electrical shock, short-circuit, or injury. 		<ul style="list-style-type: none"> ● When inspecting the pump, be sure to turn off the power supply (earth leakage circuit breaker, etc.) so that the pump may not start accidentally. Failure to do so may lead to a serious accident. 
 CAUTION			
	<ul style="list-style-type: none"> ● Do not operate the product under any voltage other than described on the nameplate with the voltage tolerance limit within $\pm 5\%$. If it is operated with a generator, it is strongly suggested not to operate other equipment with the same generator. Failure to observe this caution may cause malfunction and breakdown of the product, which may lead to electrical leakage or electrical shock. 		<ul style="list-style-type: none"> ● Do not touch the product with bare hands during or after the operation, as the product may become very hot during operation. Failure to observe this caution may lead to be burned. 
	<ul style="list-style-type: none"> ● Do not use the product in a liquid other than water. Use in oil, salt water or organic solvents will damage it, which may lead to electrical leakage or electrical shock. 		<ul style="list-style-type: none"> ● Do not run the product dry or operate it with its valve (sluice or gate valve) closed, as doing so will damage the product, which may lead to electrical leakage or electrical shock. 

 CAUTION	
	<ul style="list-style-type: none"> Do not use the product in hot or warm liquid over 40°C, as doing so will damage the product, which may lead to electrical leakage or electrical shock. 
	<ul style="list-style-type: none"> Do not allow foreign objects (metal objects such as pins or wires) to enter the suction inlet of the pump. Failure to observe this caution could cause it to malfunction or to operate abnormally, which may lead to electrical leakage or electrical shock. 
	<ul style="list-style-type: none"> When the product will not be used for an extended period, be sure to turn off the power supply (earth leakage circuit breaker, etc.). Deterioration of the insulation may lead to electrical leakage, electrical shock, or fire. 



PRECAUTIONS DURING MAINTENANCE AND INSPECTION

 WARNING	
	<ul style="list-style-type: none"> Absolutely turn off the power supply or disconnect the plug before starting maintenance or inspection. Do not work with wet hands. Failure to observe these cautions may lead to electrical shock or injury. 
	<ul style="list-style-type: none"> In case any abnormality (excessive vibration, unusual noise or odor) is found in the operation, turn the power off immediately and consult with the dealer where it was purchased or Tsurumi representative. Continuing to operate the product under abnormal conditions may result in electrical shock or fire. 
	<ul style="list-style-type: none"> Do not disassemble or repair any parts other than those designated in the operation manual. If repairs are necessary in any other than the designated parts, consult with the dealer where it was purchased or Tsurumi representative. Improper repairs can result in electrical leakage, electrical shock, or fire. 
 CAUTION	
	<ul style="list-style-type: none"> After reassembly, always perform a test operation before resuming use of the product. Improper assembly can result in electrical leakage, electrical shock, or fire. 

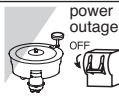
PRECAUTION TO POWER OUTAGE

 WARNING	
	<ul style="list-style-type: none"> In case of power outage, turn off the power supply. The product will resume operation when the power is restored, which presents serious danger to people in the vicinity. 

OTHER PRECAUTION

 CAUTION	
	<ul style="list-style-type: none"> Never use the product for potable water. It may present a danger to human health. 

2 NAME OF PARTS

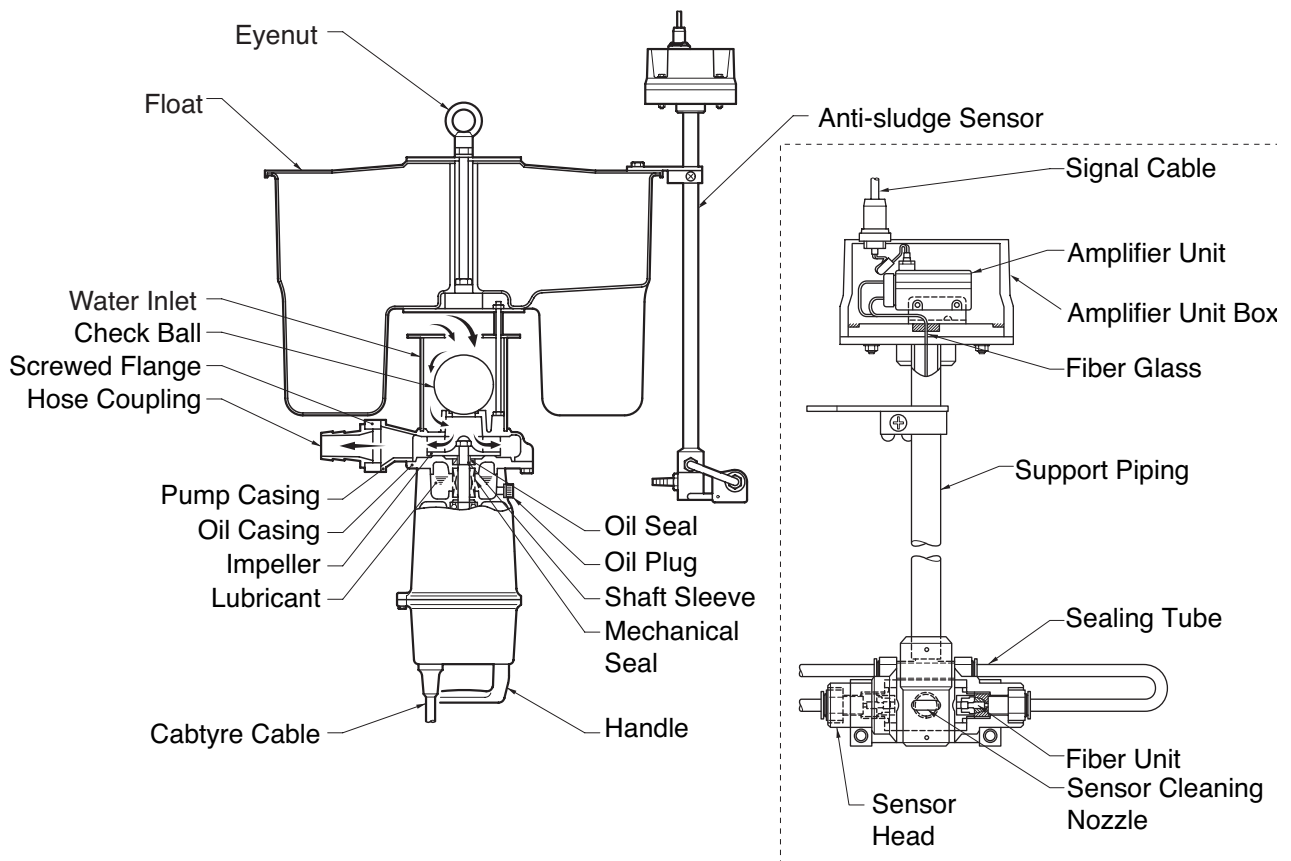

3 PRIOR TO OPERATION

When the unit is delivered, first perform the following checks.

Inspection

While unpacking, inspect the product for damage during shipment, and make sure all bolts and nuts are tightened properly.

Specification Check

Check the model number to make sure it is the product that was ordered. Be certain it is the correct voltage and frequency.

Example of nameplate

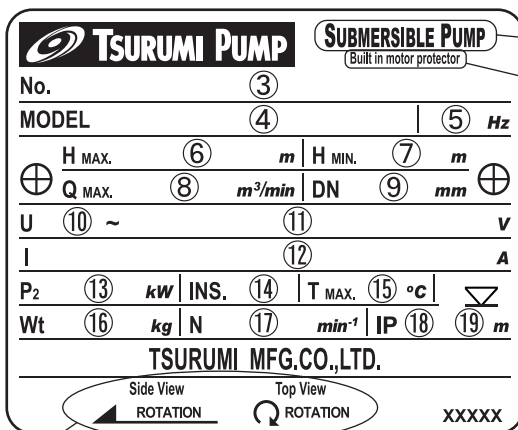

1	Submersible pump	11	Rated voltage
2	Built in motor protector	12	Rated current
3	Serial number	13	Rated output power
4	Model	14	Insulation class
5	Frequency	15	Max. liquid temperature
6	Max. total head	16	Weight without cable
7	Min. total head	17	Speed of rotation
8	Max. flow rate	18	IP degree of protection
9	Discharge bore	19	Max. immersion depth
10	Phase	20	Direction of rotation

Note: If you discover any damage or discrepancy, please contact with the Tsurumi dealer from whom you purchased the product or the nearest Tsurumi representative office.

Accessory Check

Verify that all accessory items are included in the package.

Unit Composition	QTY
Anti-sludge sensor	1
Hose coupling	1
Chain w/ Shackle (SUS304, 3m)	1
Ground name plate	1
Operation manual	1

Note: *If there is any problem with the product as shipped, contact your nearest dealer or Tsurumi representative at once.*

Product Specifications



CAUTION

Do not operate this product under any conditions other than those for which it is specified. Failure to observe this precaution can lead to electrical shock, electrical leakage, fire, water leakage or other problems.

Major Standard Specifications

Fluid	Property	Treated water, 0~40°C
Pump	Impeller	Channel Impeller
	Shaft Seal	Double Mechanical Seal
	Bearing	Shielded Ball Bearing
Motor	Specifications	Dry type submersible induction motor, 2-pole
	Insulation	Class E and F
	Protection System (built-in)	Circle thermal protector
	Lubricant	Turbine oil VG32 (additive-free)
Discharge Connection		Hose coupling

Standard Specifications (50/60Hz)

Model	Bore (mm)	Phase	Starting Method	Motor Output (kW)	Max.Head (m)	Max.Capacity m ³ /min	Debris Pass DIA (mm)	Mass (Weight) (kg)
FHP-3	40	1	Capacitor-Start	0.25	8.0 / 7.8	0.2 / 0.194	15	29
FHP-3T	40	3	Direct-on-Line	0.25	8.0 / 7.8	0.2 / 0.194	15	27
FHP-4	50	1	Capacitor-Start	0.4	10.0 / 10.2	0.28 / 0.28	15	29
FHP-4T	50	3	Direct-on-Line	0.4	10.0 / 10.2	0.28 / 0.28	15	27
FHP-8T	50	3	Direct-on-Line	0.75	13.0 / 14.0	0.42 / 0.405	15	28
FHP-15T	80	3	Direct-on-Line	1.5	11.0 / 11.0	0.81 / 0.8	15	60

Note: *The mass (weight) given above is the dry weight of the pump itself, not including the cable.*

Anti-Sludge Sensor Specifications

Type	Beam penetration type
Supply Voltage	DC10~30V
Consumption Amperage	25mA
Beam Source	Red LED
Response Speed	250μs
Operation Mode	Operating with beam input: selector switch at "L"
Control Output	NPN open collector output
Allowable Load Supply Voltage	MAX.30VDC
Allowable Load Amperage	MAX.100mA
Sensitivity Adjuster	10-turn dial
Indicator Light	Output indicator light: orange LED; safety indicator light: green LED
Connection Type	Pull-out cord
Operating Ambient Brightness	Sunlight: 10,000 lux max., incandescent lamp: 3,000 lux max.
Operating Ambient Temperature	-25°C~+55°C
Operating Ambient Humidity	Operation: 35 - 85%; storage: 35 - 90% (individual amp)
Insulation Resistance	20 MΩ min. (at DC 500V) between power line - outer case
Withstand Voltage	AC 1,000V 50/60Hz, 1 minute, between power line - outer case

4 INSTALLATION

CAUTION

- Do not use this product in liquids other than water, such as oil, salt water, or organic solvents.
- Use with a power supply voltage tolerance within $\pm 5\%$ of the rated voltage.
- Do not use in water temperatures outside the range of 0 ~ 40°C, which can lead to failure, electrical leakage or shock.
- Use only in fully assembled state.

Note: Consult your local dealer or Tsurumi representative before using with any liquids other than those indicated in this document.

Critical Use Pressure

CAUTION

Do not operate the pump in an area that is exposed to a water pressure that exceeds the values given below.

Applicable Pump	Critical Use Pressure
Models with output of 0.75kW or under	0.2MPa (2kgf/cm ²) — discharge pressure during use
Models with output of 1.5kW	0.3MPa (3kgf/cm ²) — discharge pressure during use

Preparing for installation

Prepare a suitable chain or rope for the pump. Refer to the weight of each pump described in the table of "Standard Specifications (50/60Hz)" on Page 6.

Before installing the product at a work site, you will need to have the following tools and instruments ready:

- Insulation resistance tester (megohmmeter)
- AC voltmeter
- AC ammeter (clamp-on type)
- Bolt and nut tighteners
- Power supply connection tools (screwdriver or box wrench)
- Cabling stakes (for use with cable and chain)

Note: Please read also the instructions that come with each of the test instruments.
Please use banding bands that is made of polypropylene.

Checks to make before installation

Single-phase power supply:

Use a megger to measure the resistance between the tip of the cabtyre cable plug and the ground terminal to verify the insulation resistance of the motor.

Three-phase power supply:

Use a megger to measure the resistance between each core of the cabtyre cable and the (green) ground wire to verify the insulation resistance of the motor.

Insulation resistance reference value
= 20M Ω minimum

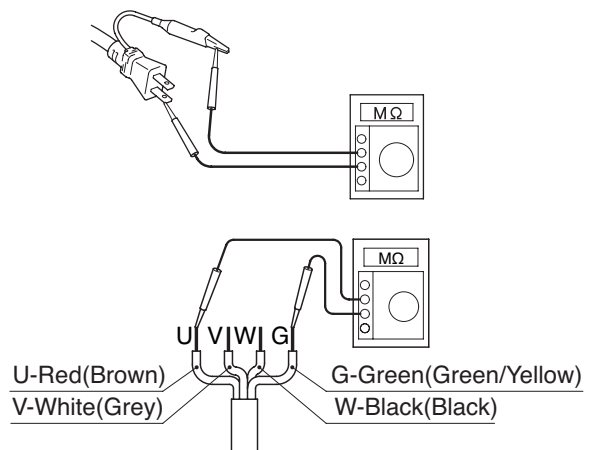

Note: The insulation resistance reference value of 20M Ω minimum is based on a new or repaired pump. For reference values of a pump that has already been put into operation, refer to "7. Maintenance and Inspection" of this manual.

CAUTION

Never use a megger to measure the insulation resistance between the cores of the anti-sludge sensor wires. Using a megger could damage the built-in amplifier.

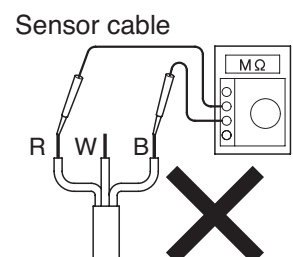

Precautions in installation

WARNING When installing the pump, be mindful of the pump's center of gravity and weight. If the pump is not suspended properly, the pump may fall and break, which may lead to injury.

CAUTION When installing or moving the pump, never suspend the pump by the cabtyre cable. Doing so will damage the cable, which may cause a current leakage, electrical shock, or fire.

Refer to the installation examples illustrated below and pay attention to the points described below to install the pump.

CAUTION During piping work if the welding sparks, paint, or concrete come in contact with the pump, they could cause the pump to malfunction, which may lead to current leakage or electrical shock.

- (1) When transporting or installing the pump, do not kink the cabtyre cable or use it in place of a rope.
- (2) Keep the planned (effluent) water level fluctuation in mind when handling the cabtyre cable or the lifting chain. Lift it slightly and secure it to a hook (if no guide rail is used, a hook must be prepared in advance by placing it on the frame of a manhole or the like).

CAUTION Do not operate the pump with a cabtyre cable, rope, or chain dangling. Failure to observe this precaution may cause the cabtyre cable, rope, or chain to become wrapped around the pump unit, causing the pump to operate improperly or malfunction.

Securing the Pump with a Chain

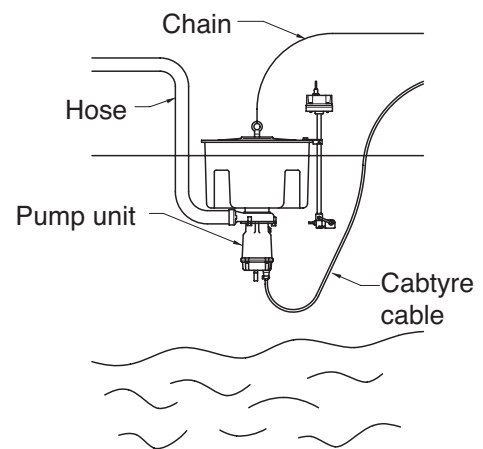

- (3) The stopper on the guide rail is intended to prevent the pump from falling. If the pump is lowered more than necessary, it will pull on the cabtyre cable, causing an open circuit. To prevent it, make sure to install the stopper on the guide rail.
- (4) For the guide rail, use 25A-SUS304TP-Sch10S pipes, and cut them locally to a length that is suitable for the depth of the sump.

Securing the Pump with a Guide Rail

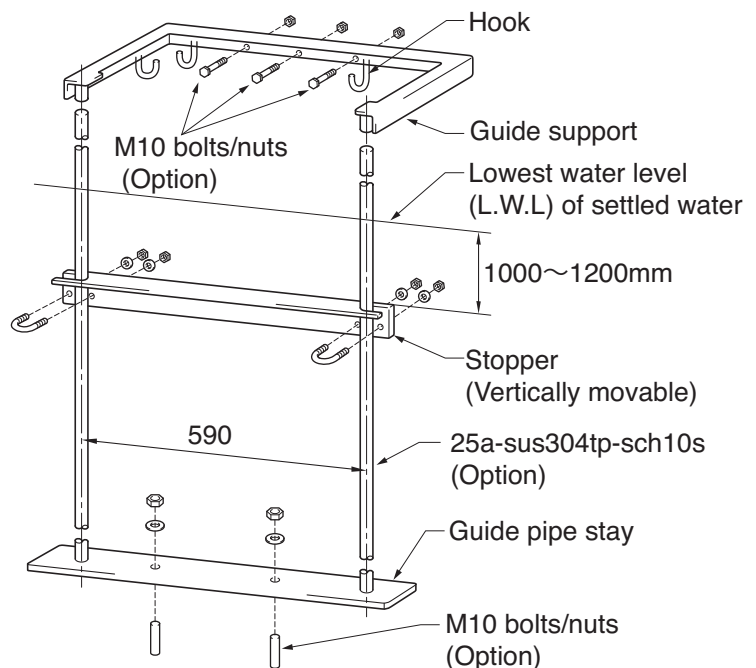

■ Pump Unit

- (1) Set the detector portion of the anti-sludge sensor lower than the suction inlet of the pump.
- (2) For the discharge hose (which is not supplied), use a braid-reinforced, suction-delivery PVC hose. Use a hose clamp to attach it securely to the discharge outlet. Keep the planned (effluent) water level fluctuation in mind when determining the length of the hose.

CAUTION To install the discharge hose, first lower the FHP unit until it comes in contact with the stopper. With the FHP in this position, install the discharge hose without creating slack. If there is slack in the hose, the FHP unit may become tilted.

- (3) For the sensor cleaning water hose (which is not supplied), use a 15mm bore, braid-reinforced PVC hose. Attach the sensor cleaning nozzle securely with a hose clamp.

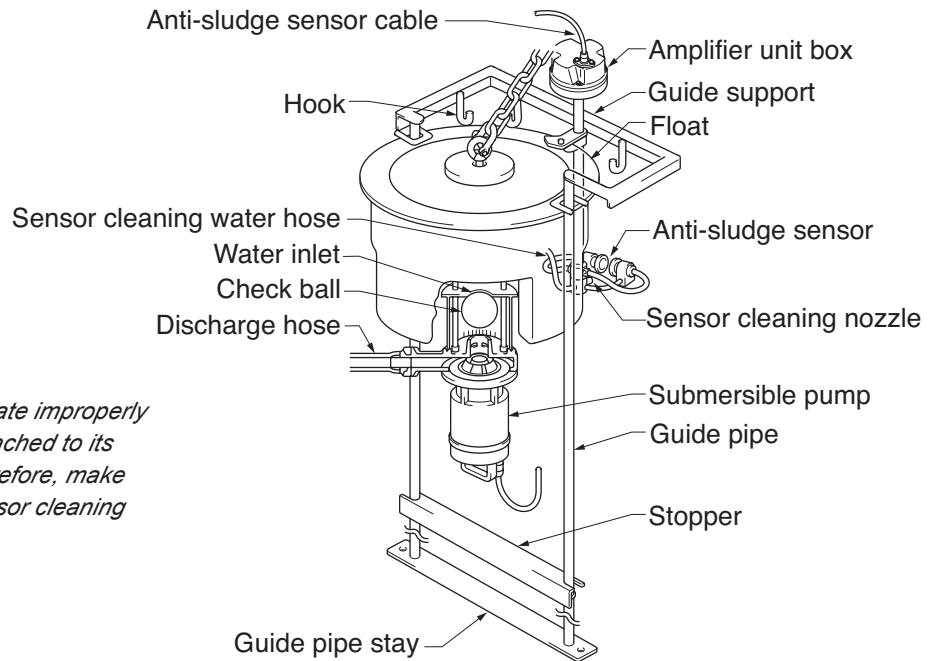

Note: *The sensor may operate improperly if debris becomes attached to its detector portion. Therefore, make sure to install the sensor cleaning nozzle.*

- (4) Place the pump in an area with an ample water level or where water is likely to accumulate.

Note: *Refer to the "Water Level" section on page 14 for the water level during operation. Do not submerge the end of the discharge hose in the water because this can cause the water to backflow due to the siphon effect. The discharge hose and the sensor cleaning water hose are not supplied with the product.*

■ Attaching a Chain or Rope to Suspend the Pump

Refer to the illustration on the right in order to suspend the pump by a chain.

CAUTION Make sure the lifting chain does not become twisted during installation. Failure to observe this precaution could cause the chain to break, the pump to fall and break, which could lead to injury. When you mount shackles, be also careful so that the eye-bolt (pin) may not get dislocated, by means of providing a stainless steel wire or tying band.

CAUTION Make sure the lifting chain does not become loosened. If the chain comes in contact with the pump, it could cause the pump to wear, the paint to peel, or the chain to wear.

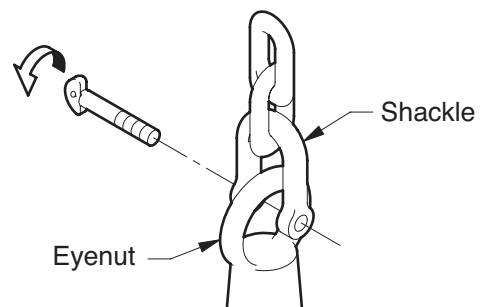

5 ELECTRICAL WIRING

Performing electrical wiring

- WARNING**
- Electrical wiring should be performed by a qualified person in accord with all applicable regulations. Failure to observe this precaution not only risks breaking the law but is extremely dangerous.
 - Incorrect wiring can lead to electrical leakage, electrical shock or fire.
 - Absolutely provide a dedicated earth leakage circuit breaker and a thermal overload relay suitable for the pump (available on the market). Failure to follow this warning can cause electrical shock or explosion when the product fails or an electrical leakage occurs.

Operate well within the capacity of the power supply and wiring.

Grounding

- WARNING** Do not use the product without first grounding it properly. Failure to ground it can lead to electrical shock from an electrical leak or malfunction.

- CAUTION** Do not attach the grounding wire to a gas pipe, water pipe, lightning arrester or telephone grounding wire. Improper grounding can result in electrical shock.

Connecting the power supply

- WARNING** Before inserting the power plug or connecting the wires to the terminal board, make sure that the power supply (i.e. circuit breaker) is properly disconnected. Failure to do so may lead to electrical shock, short, or injury caused by the unintended starting of the pump.

- CAUTION** Do not use damaged cable cables, power plugs, or loose power outlets. Failure to observe this precaution could lead to electrical shock, short circuit, or fire.

Follow the diagram on the right to connect the power.

When using a three-prong grounded plug, connect as shown in the drawing.

- CAUTION** Be sure to use a dedicated power supply with a ground leakage circuit breaker.

When a three-phase power source is used, connect the leads to the control panel terminals as shown in the diagram, making sure they do not become twisted together.

Note: The cable, if it is unused, is terminally processed. If there is a need to peel off the cable again, have the terminal processed.

Single-Phase

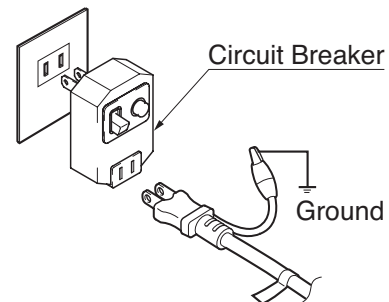

Three-Phase

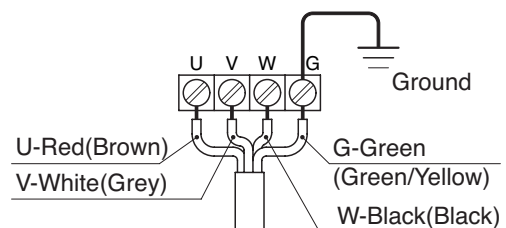

Electrical Circuit Diagrams

Condenser Starting

Power Supply: Single-Phase

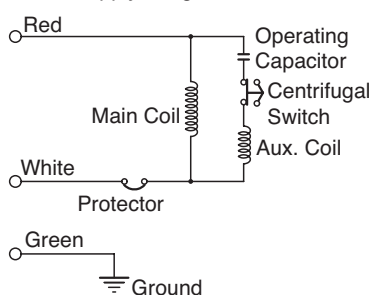

Direct-on-line Starting

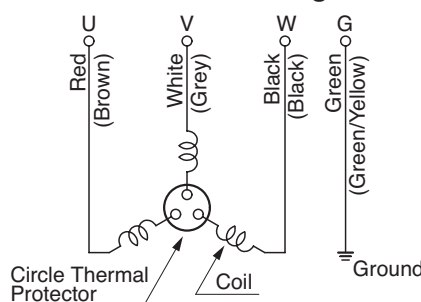

Anti-Sludge Sensor

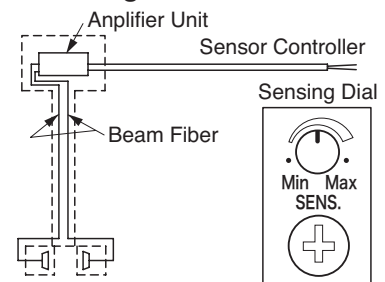

- * The sensitivity of the amplifier unit can be adjusted to suit the density of the sludge (by way of its beam penetration rate). To do so, remove the cover from the amplifier unit box and adjust the "sensing dial" located on top of the amplifier unit. The sensing dial, which is factory-set to its middle position, should be adjusted to suit the field conditions after the sludge has settled in the sump. For a detailed procedure for adjusting the sensor, refer to the "Anti-Sludge Sensor Adjustment" section on page 18.

Anti-Sludge Sensor

The anti-sludge sensor, which is attached to the FHP series submersible decanting pump, senses the settled water layer. The beam emitter transmits a beam via the beam fiber. This beam passes through the sludge fluid and reaches the beam receiver. When the sludge is diffused in the fluid, the sensor's output transistor is OFF. When the sludge is settled in the fluid, the sensor's output transistor is ON. These signals are transmitted to the control circuit in the control panel in order to prevent the sludge from flowing out and allow only the upper clear water to be discharged.

Connecting Anti-Sludge Sensor

The diagram below shows an example of an anti-sludge sensor circuit. A similar circuit should be created in the control panel.

Using Omron S3D2-CK model controller :

Settings : IN1 : NORM / MODE : OR / TIMER : ON / RANGE : 10S / TIMER MODE : ON / TIME ADJ : 3S

To use a controller other than the above, contact the dealer where this product was purchased, or the Tsurumi sales office in your area.

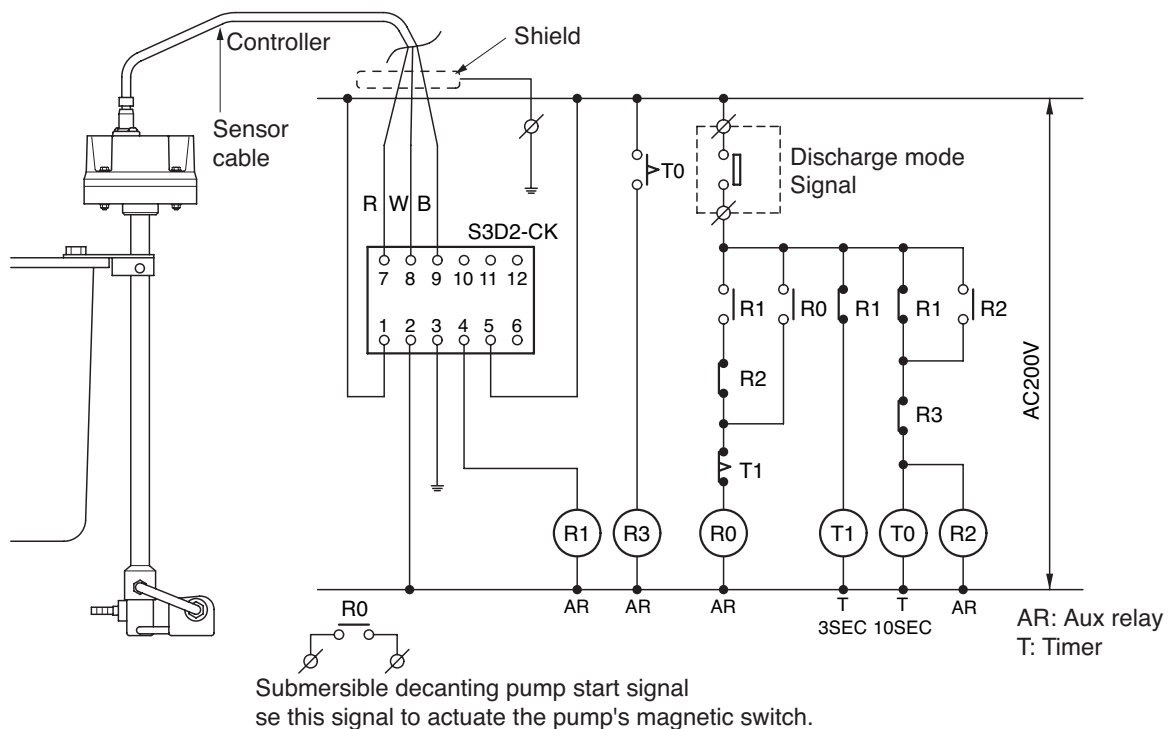

Connect the core wires (black, red, and white) supplied with the anti-sludge sensor to the respective terminal numbers of the sensor controller.

Note: *When routing the cables, keep the cable and the anti-sludge sensor cable a minimum of 20cm apart. Also, be sure to use separate conduits for the cables.*

Be sure to provide a dedicated circuit in the control panel and securely connect the shield for the anti-sludge sensor cable to that circuit.

After completing the connections, operate the pump dry. Place a barrier (hand or wooden plate) between the beam sensors to make sure the pump stops.

6 OPERATION

Before starting

- (1) Check the model name plate to make sure once again that the product is of the correct voltage and frequency rating.

CAUTION Using the product at other than rated voltage and frequency will not only lower its performance but may damage the product.

- (2) Confirm the wiring, supply voltage, circuit breaker capacity, and motor insulation resistance.

Reference insulation resistance = 20MΩ or greater

Note: *The reference insulation resistance (20MΩ or greater) is the value when the product is new or has been repaired. For the reference value after installation, see below at "Maintenance and Inspection" on page 14.*

- (3) The setting on the circuit breaker or other overload protector should be made in accord with the rated current of the product.

Note: *See the model name plate on the product for its rated current.*

Test operation

WARNING

- Never operate the product while it is suspended in the air. The recoil may result in injury or other major accident.
- Never start the product when people are standing next to it. An electrical leak can result in electrical shock.

- (1) Run the product for a short time(1~2 seconds) to check the direction of rotation. The rotation is correct if the product recoil direction is counter-clockwise.

CAUTION Always perform the rotation check in air, not while the product is submerged. Running the product in reverse direction while submerged may damage the product, resulting in electrical leakage or electrical shock.

- (2) If the direction is reversed, correct it using the countermeasure shown below.

WARNING Before changing the connections to correct the rotation, be sure to turn off the power supply (circuit breaker), and make sure the impeller has stopped completely, to avoid electrical shock or shorting.

COUNTERMEASURE

(Direct-on-line start models):

Interchange connections between any two of the three leads U, V, or W.

- (3) Run the product for a short time (3~10minutes) and confirm the following.
Using an ammeter(clamp-on type), measure the operating current at the U, V, and W phase leads on the terminals.
Using an AC voltmeter(tester), measure voltage at the terminals.
Supply voltage tolerance: within ± 5% of rated voltage.

COUNTERMEASURE

If the operating current exceeds the rated value, motor overload may be a cause. Make sure the product has been installed under proper conditions as described in the section on Installation (p.7)

COUNTERMEASURE

If the supply voltage is outside the variation, possible causes are the power supply capacity or an inadequate extension cable. Look again at the section on Electrical Wiring (p.10) and make sure the conditions are proper.

CAUTION In case of very excessive vibration, unusual noise or odor, turn off the power immediately and consult with your nearest dealer or Tsurumi representative. Continuing to operate the product under abnormal conditions may result in electrical shock, fire, or electrical leakage.

Operation

WARNING The pump unit may be extremely hot during operation. To prevent burns, do not touch the pump unit with bare hands during or after the operation.

Pay attention to the water level during the pump operation. The pump will become damaged if it is allowed to operate dry.

Due to an overload operation or a pump malfunction, if the motor protector trips to stop the pump, make sure to eliminate the cause of the problem before restarting.

A frequent ON/OFF will shorten the lifetime of the pump.

To operate a submersible pump (including automatic operation), set the water level so that the pump will operate approximately less than 10 times per hour.

Note: A large amount of amperage flows when a submersible pump is started, causing the temperature of its windings to rise rapidly. Beware that a frequent stop-and-go operation of the pump will accelerate the deterioration of the insulation of the motor windings and thus affect the use life of the motor.

Actuating the Anti-Sludge Sensor

The anti-sludge sensor prevents sludge from being discharged out of the sump when it senses a sludge layer while the pump is discharging the upper layer of clear water.

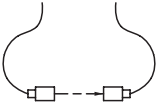
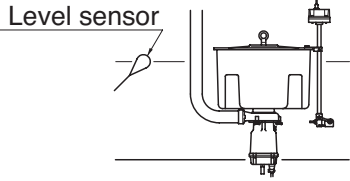
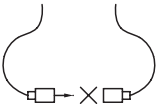
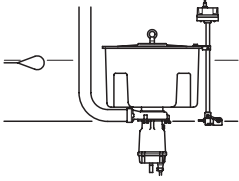
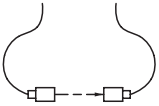
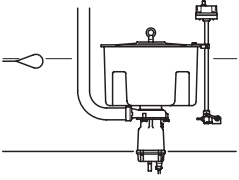
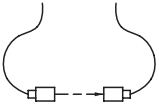
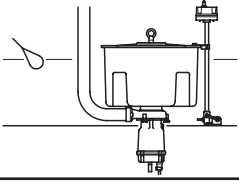
Sensor	Pump	Level Sensor	Water Level
Beam penetrating 	Starts	ON	
Beam not penetrating (senses sludge layer) 	Stops	ON	
Beam penetrating 	Restarts	ON	After 10 minutes 
Beam penetrating 	Stops	OFF	

*The flow rate per discharge is determined by the control range of the level sensor.

Cleaning the Anti-Sludge Sensor

The sensor of this pump may operate improperly if sludge becomes attached to its detector portion. Be sure to attach a cleaning hose to ensure proper cleaning.

Note: The sensor lenses are self-cleaned through the convection of water pressure. Do not attempt to check this operation on the ground.

- (1) Use a soft, 15mm flexible hose for piping.
- (2) Take cleaning water from defoamed (or clear) water supply.
- (3) Clean for 5 minutes hourly at operating temperature. Regulate the valve to the cleaning water to attain a flow rate of 10 to 20 L/min and a pressure of 0.05 to 0.1 MPa.

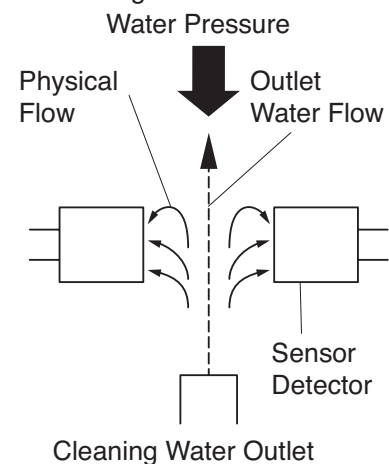

Water Level During Operation

Adjust the sensor to a position of the sludge layer level that is being detected. There is no risk of the pump drawing the settled sludge, provided that the sensor is positioned below the bottom of the float. However, the adjustable range (H1) is 50 to 170mm below the bottom of the float. After the pump starts and the sensor detector has reached the sludge layer level, the water depth (H2) will be 260 to 390mm.

Note: For a detailed procedure for adjusting sensor sensitivity, refer to the "Anti-Sludge Sensor Adjustment" section on page 18.

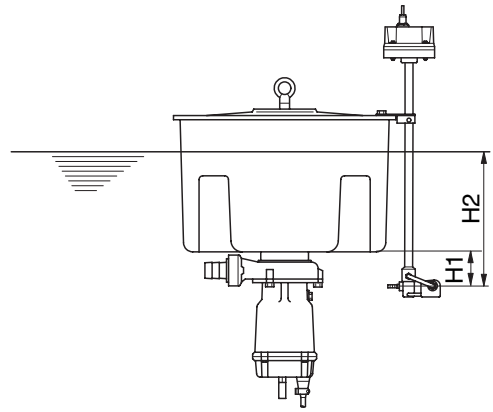

Motor Protector

The pump is equipped with a built-in motor protector (circle thermal protector).

If a current overload or overheating occurs under the symptoms given below, the pump will stop automatically to protect the motor regardless of the water level at the time of operation.

- Extreme fluctuation of power supply voltage
- Pump operated under overload condition
- Pump operated at open phase or binding condition

Note: After the motor protector has tripped, the motor automatically resumes its operation. Therefore, make sure to disconnect the cable from the terminal board or the power outlet, and eliminate the cause of the problem.

Do not operate the pump at unusually low head, or with the impeller clogged with debris. Doing so will not only prevent the pump from attaining its full potential, but may also generate abnormal noise and vibration and damage the pump.

7 MAINTENANCE AND INSPECTION

Regular maintenance and inspection are indispensable to maintaining the pump's performance. If the pump behaves differently from its normal operating condition, refer to section "9. Troubleshooting" and take appropriate measures at an early stage. We also recommend that you have a spare pump on hand for an emergency.

Prior to Inspection



WARNING Make sure that the power supply (i.e. circuit breaker) is disconnected and disconnect the cable from the power outlet or remove it from the terminal board. Failure to do so may cause electrical shock or unintended starting of the pump, which may lead to serious accidents.

- (1) Washing
Remove accumulated matter from the surface of the unit and wash it with clean water. Take special care to remove any debris from the impeller.
- (2) Inspecting the exterior
Look for any peeling or chipped paint, and make sure the nuts and bolts are fastened securely. Any cracks in the surface should be repaired by cleaning that area, drying it and then applying a touchup coating.

Note: Touchup is not supplied. Some kinds of damage or looseness may require that the unit be disassembled for repairs. Please consult with your nearest dealer or Tsurumi representative.

Daily and Periodic Inspection

Interval	Inspection Item	
Daily	<ul style="list-style-type: none"> ■ Measure operating current ■ Measure power voltage 	<ul style="list-style-type: none"> ● To be below the rated current. ● Power supply voltage tolerance (within $\pm 5\%$ of the rated voltage)
Monthly	<ul style="list-style-type: none"> ■ Measure insulation resistance <p><i>Note: If the insulation resistance has become notably lower than the previous inspection, an inspection of the motor will be necessary.</i></p>	<ul style="list-style-type: none"> ● Reference insulation resistance = $1M\Omega$ or greater
Semi-yearly	<ul style="list-style-type: none"> ■ Inspecting the pump ■ Hose inspection ■ Checking the detector portion of the sensor ■ Checking the sensor cleaning nozzle ■ Inspection of lifting chain or rope ■ Oil inspection <p><i>Note: Refer to details of oil inspection and oil change (p.15)</i></p>	<ul style="list-style-type: none"> ● A noticeable drop in performance may indicate wear in the impeller, etc., or else clogging of the impeller, etc. Remove the clogged debris, and replace any worn parts. ● Check that the hose connectors are free of cracks. ● Make sure there is no debris wound around or attached to the sensor. Also, check that the beam emitting and receiving faces have not shifted. The orange lamp in the amplifier unit box will illuminate if the sensor is receiving the beam. ● Make sure the cleaning nozzle is not clogged. If it is clogged, increase the cleaning frequency. ● Replace if damage, corrosion, or wear has occurred to the chain or the rope. Remove if foreign object is attaching to it. ● Check the oil every 12 months or after 1,500 hours of use, whichever comes first.
Yearly	<ul style="list-style-type: none"> ■ Change oil ■ Change mechanical seal <p><i>Note: Refer to details of oil inspection and oil change (p.15)</i> <i>Note: Specialized know-how is required for inspecting and replacing the mechanical seal. Consult with your nearest dealer or Tsurumi representative.</i></p>	<ul style="list-style-type: none"> ● Change the oil every 24 months or after 3,000 hours of use, whichever comes first. Designated oil : Turbine Oil VG32 (Additive-free)
Every 2 to 5 years	<ul style="list-style-type: none"> ■ Overhaul 	<ul style="list-style-type: none"> ● This should be carried out even if there are no problems with the product. The frequency depends on how continuously the product is in use. <p><i>Note: Consult with your nearest dealer or Tsurumi representative.</i></p>

Note: *In case the pumping liquid contains oil, paint, or slurry, it may cause the swelling of cable jacket or abrasion of the mechanical seal's sealing face, which will result in the pump fault, it is strongly recommended to inspect earlier.*

Storage

Note: *When the unit is out of use for an extended period, wash it and dry it thoroughly, then store it indoors. Always run a test operation before putting the unit back into service.*

If the unit is left in the water, it should be run at a minimum of once a week.

Oil inspection and Oil change

Inspecting Oil

Remove the oil plug and tilt the unit to drain a small amount of oil. If the oil is milky white or has water mixed in with it, the mechanical seal may be faulty. In this case the unit will need to be disassembled and repaired.

Replacing Oil

Remove the oil plug and drain all the oil, then replace it with the specified amount of oil as shown in the table.

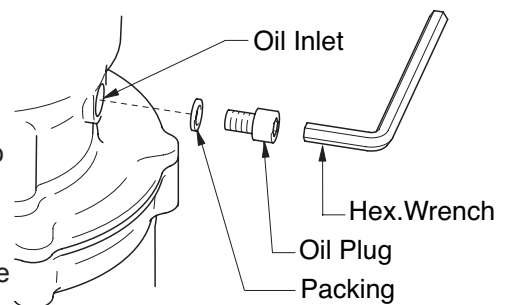

Note: *Worn oil and other waste products should be disposed of by a qualified agent, in accord with applicable laws. The oil plug packing and O-ring should be replaced each time the oil is inspected or changed.*

Applicable Model	Specified Volume
Model with 0.25 ~ 0.4kW power output	190
Model with 0.75kW power output	420
Model with 1.5kW power output	1,050

Unit : ml

Replacement Parts

The table lists the parts that need to be replaced periodically. Replace these using the recommended frequency as a guideline.

Part	Recommended Frequency
Mechanical Seal	When oil becomes milky.
Oil (Turbine Oil VG 32 (Additive-free))	Every 12 months or after 3,000 hours of use, whichever comes first.
Packing, O-Ring	Each time unit is disassembled or inspected
Oil Seal	When lip is worn, and each time unit is disassembled or inspected
Shaft Sleeve	If worn

8 DISASSEMBLY AND REASSEMBLY PROCEDURE

■ Prior to Disassembly and Reassembly



WARNING

Before disassembling and reassembling the pump, be sure that the power supply (i.e. circuit breaker) is disconnected, and remove the cabtyre cable from the outlet or the terminal board. Do not connect or disconnect the power plug with a wet hand, in order to prevent electrical shock. Do not perform an activation test (to check the rotation of the impeller) during disassembly and reassembly. Failure to observe this precaution could lead to a serious accident, including injury.

This section explains the disassembly and reassembly processes that are involved up to the replacement of the impeller itself. Operations involving the disassembly and reassembly of the sealing portion (i.e. mechanical seal) and of the motor require a specialized facility including vacuum and electrical test equipment. For these operations, contact the dealer where this equipment was purchased, or the Tsurumi sales office in your area.

Disassembly Procedure

Note: *Before disassembling, be sure to drain the oil from the pump.*

- (1) Removing the pump unit
Remove the eyenut, hex nut, spring washer, and adapter. Then, take out the pump unit from the float set.
- (2) Removing the pump casing
Remove the supporter, water suction pipe, and check ball from the pump unit. Remove the hex bolts, and take out the pump casing and packing from the oil casing.
- (3) Removing the impeller
Using a box wrench, remove the impeller nut and spring washer; then, remove the impeller and the impeller adjustment washer from the main shaft.

Disassembly Diagram

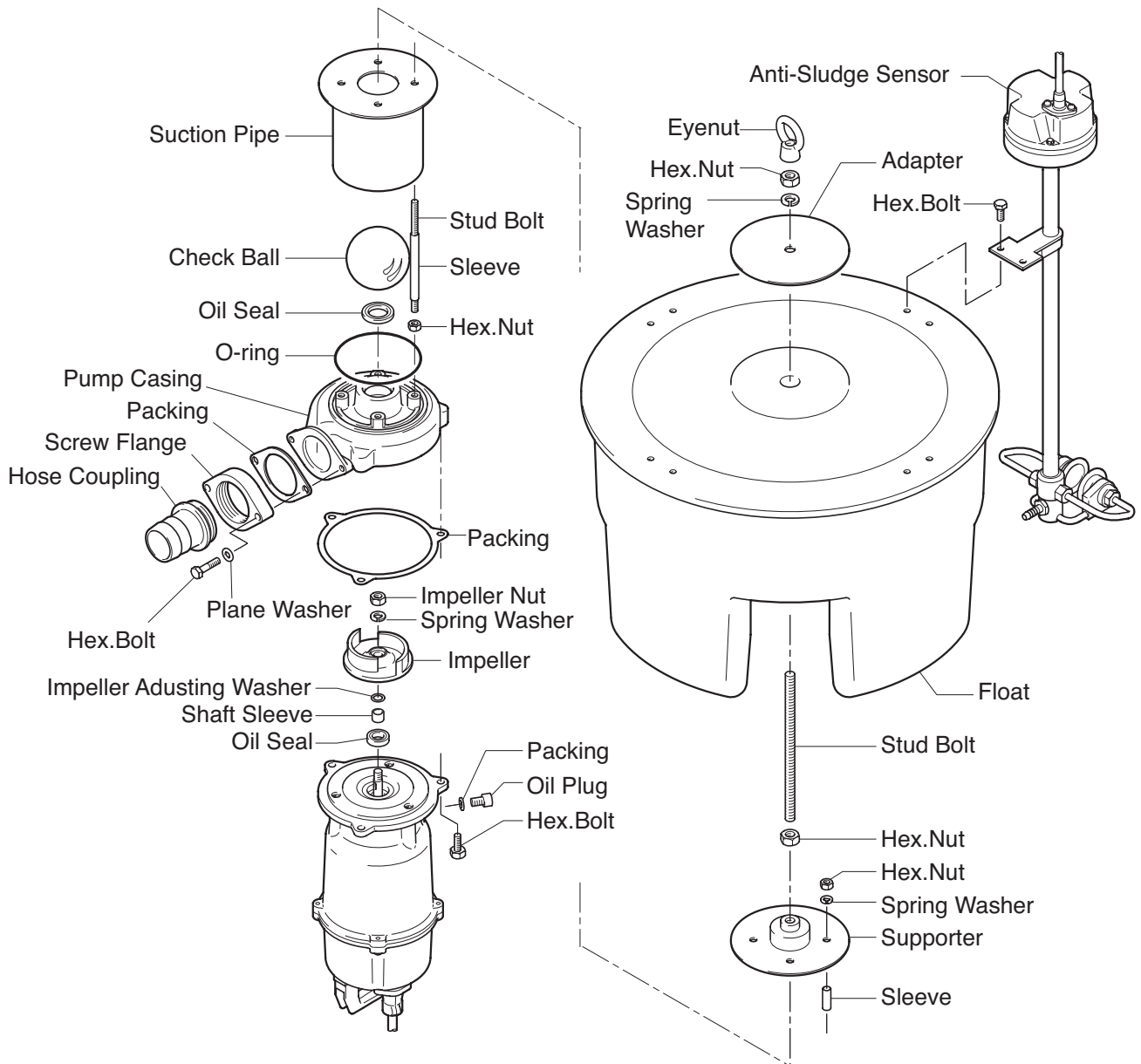

Note: *The above disassembling block diagram is a typical one, and there may be some differences from actual shapes or compositions depending on models.*

Reassembly Procedure

Reassembly can be performed by reversing the steps for disassembly.

Note: *After reassembling the pump, be sure to fill it with the required amount of oil. Replace the packing with new parts. Replace any other worn or damaged parts as well.*

After attaching the impeller, and again after assembly is completed, check to make sure the impeller rotates smoothly and that it does not rub against the pump casing.

Anti-Sludge Sensor Adjustment

Adjust the sensing dial as follows:

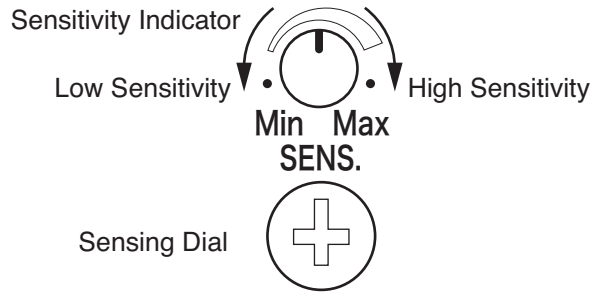

ADJUSTMENT METHOD

Step	Beam Penetrating Or Not Penetrating	Adjustment Method	Sensitivity Indicator	Output Indicator Light
1	—	Adjust the sensing dial to "Min".	 Min Max SENS.	—
2	Beam not penetrating 	This step is performed while the beam is not penetrating. Turn the sensing dial to the right to find the point (referred to as "point A") at which the output indicator light turns ON. (If the light does not turn ON or OFF, the point at which the sensing dial stops turning is referred to as "point A".)	 Min Max SENS.	 (Orange)
3	Beam penetrating 	The next step is performed while the beam is penetrating. Turn the sensing dial to the left to find the point (referred to as "point B") at which the output indicator light turns OFF. (If the light does not turn OFF or ON, the point at which the sensing dial stops turning is referred to as "point B".)	 Min Max SENS.	(Orange) —
4	—	Adjust the sensing dial so that the sensitivity indicator comes between points A and B.	Set Position Min Max SENS.	—
5	Check that the stable detection level indicator light turns ON regardless of whether the beam is penetrating or not.			

9 TROUBLESHOOTING

⚠ WARNING To prevent serious accidents, disconnect the power supply before inspecting the pump.

Read this Operation Manual carefully before requesting repair. After re-inspecting the pump, if it does not operate normally, contact the dealer where this equipment was purchased, or the Tsurumi sales office in your area.

Problem	Possible cause	Countermeasure
Pump fails to start	(1)No power supply (power outage, etc.) (2)Disconnection or inadequate connection of cable. (3)Foreign object lodging on impeller (4)Low voltage. (5)Anti-sludge sensor circuit has tripped.	(1>Contact the power company or an electrical repair shop. (2)Check if the cable or wiring is disconnected. (3)Check and remove any debris. (4)Provide the rated voltage. (5)Check the circuit.
Pump stops during operation.	(1)Pump's built-in motor protector trips cyclically. (2)Anti-sludge sensor circuit has tripped.	(1)Remove the debris jammed in the impeller. (2)Check the circuit.
Low performance or performance decreases	(1)Low voltage or voltage drop. (2)Impeller rotates in reverse direction. (3)The piping is partially blocked. (4)Impeller is worn. (5)Suction inlet is clogged.	(1)Provide the rated voltage. (2)Interchange the power supply leads (p. 12). (3)Remove the blockage. (4)Replace the worn parts. (5)Remove the blockage.
Sensor detector is not effecting control.	(1)Control circuit is improper. (2)Debris is adhering onto the beam emitting and receiving faces. (3)Beam emitting and receiving faces have shifted. (4)There is an open circuit in the optical fibers. (5)There is an open circuit in the cable.	(1)Correct the circuit. (2)Clean the faces. (3)Realign the faces. (4)Replace the fibers. (5)Replace or reconnect the cable.

Disposal Product

Properly dispose of the product by disassembling it, presorting the contents, and sending them to the waste material treatment site.

The following information is required when ordering repairs or making other inquiries.

Product model	
Manufacturing number	
Purchase date	
Remarks	