

**Submersible Mixer**

# MR200/300/400 Series

## OPERATION MANUAL

**INTRODUCTION**

Thank you for selecting the Tsurumi Submersible Mixer.

This equipment should not be used for applications other than those listed in this manual. Failure to observe this precaution may lead to a malfunction or an accident. In the event of a malfunction or an accident, the manufacturer will not assume any liability. After reading this Operation Manual, keep it in a location that is easily accessible, so that it can be referred to whenever information is needed while operating the equipment.

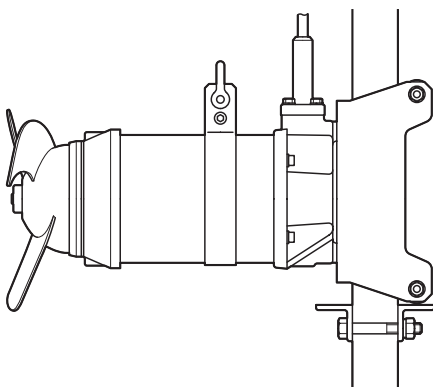
**CONTENTS**

1. BE SURE TO READ FOR SAFETY .....	1
2. PART NAMES.....	4
3. PRIOR TO OPERATION .....	5
4. INSTALLATION .....	7
5. ELECTRICAL WIRING .....	8
6. OPERATION.....	10
7. MAINTENANCE AND INSPECTION.....	13
8. TROUBLESHOOTING .....	15

# 1 BE SURE TO READ FOR YOUR SAFETY

Be sure to thoroughly read and understand the SAFETY PRECAUTIONS given in this section before using the equipment in order to operate the equipment correctly.

The precautionary measures described in this section are intended to prevent danger or damage to you or to others. The contents of this manual that could possibly be performed improperly are classified into two categories: **⚠ WARNING**, and **⚠ CAUTION**. The categories indicate the extent of possible damage or the urgency of the precaution. Note however, that what is included under **⚠ CAUTION** may at times lead to a more serious problem. In either case, the categories pertain to safety-related items, and as such, must be observed carefully.









- **⚠ WARNING** : Operating the equipment improperly by failing to observe this precaution may possibly lead to death or injury to humans.
- **⚠ CAUTION** : Operating the equipment improperly by failing to observe this precaution may possibly cause injury to humans and other physical damage.
- **NOTE** : Gives information that does not fall in the WARNING or CAUTION categories.
- **Explanation of Symbols:**
  - ⚡ : The ⚠ mark indicates a WARNING or CAUTION item. The symbol inside the mark describes the precaution in more detail ("electrical shock", in the case of the example on the left).
  - ⊘ : The ⊘ mark indicates a prohibited action. The symbol inside the mark, or a notation in the vicinity of the mark describes the precaution in more detail ("disassembly prohibited", in the case of the example on the left).
  - ⏚ : The ● mark indicates an action that must be taken, or instructs how to perform a task. The symbol inside the mark describes the precaution in more detail ("provide ground work", in the case of the example on the left).

## PRECAUTIONS TO THE PRODUCT SPECIFICATIONS

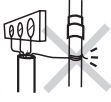















<b>⚠ CAUTION</b>	
	<p>● Do not operate the product under any conditions other than those for which it is specified. <b>Failure to observe the precaution can lead to electrical leakage, electrical shock, fire, or water leakage, etc.</b></p>

## PRECAUTIONS DURING TRANSPORT AND INSTALLATION





<b>⚠ WARNING</b>			
	<p>● When transporting the product, pay close attention to its center of gravity and mass. Use an appropriate lifting equipment to lift the unit. <b>Improper lifting may result in the product damage, injury, or death.</b></p>		<p>● Install the product properly in accordance with this instruction manual. <b>Improper installation may result in electrical leakage, electrical shock, fire, water leakage, or injury.</b></p>
	<p>● Electrical wiring should be performed in accordance with all applicable regulations in your country. <b>Absolutely provide a dedicated earth leakage circuit breaker and a thermal overload relay suitable for the product (available on the market). Imperfect wiring or improper protective equipment can lead to electrical leakage, fire, or explosion in the worst case.</b></p>		<p>● Provide a secure grounding dedicated for the product. Never fail to provide an earth leakage circuit breaker and a thermal overload relay in your starter or control panel (Both available on the market). <b>If an electrical leakage occurs by due to a product failure, it may cause electrical shock.</b></p>

 <b>CAUTION</b>	
 <ul style="list-style-type: none"> <li>● Be sure to provide a ground wire securely. Do not connect the ground wire to a gas pipe, water pipe, lightning rod, or telephone ground wire. <b>Improper grounding could cause electrical shock.</b></li> </ul> 	 <ul style="list-style-type: none"> <li>● This mixer is neither dust-proof nor explosion-proof. Do not use it at a dusty place or at a place where toxic, corrosive or explosive gas is present. <b>Use in such places could cause fire or explosion.</b></li> </ul>
 <ul style="list-style-type: none"> <li>● Do not scratch, fold, twist, make alterations, or bundle the cable, or use it as a lifting device. <b>The cable may be damaged, which may cause electrical leakage, short-circuit, electrical shock, or fire.</b></li> </ul> 	 <ul style="list-style-type: none"> <li>● Do not use the cabtyre cable if it is damaged. Connect every conductor of the cabtyre cable securely to the terminals. <b>Failure to observe this can lead to electrical shock, short-circuit, or fire.</b></li> </ul> 
 <ul style="list-style-type: none"> <li>● When transporting the mixer, pay close attention to the center of gravity and weight. <b>Imbalanced or unsteady lifting may cause falling down of the unit, which may lead to breakdown or injury.</b></li> </ul>	



## PRECAUTIONS DURING TEST OPERATION AND OPERATION

 <b>WARNING</b>	
 <ul style="list-style-type: none"> <li>● Never try to operate the mixer if somebody is present in the tank. <b>If an electrical leakage occurs, it can cause electrical shock.</b></li> </ul>	 <ul style="list-style-type: none"> <li>● Never start the mixer while it is suspended, as <b>the unit may jerk and could lead to injury.</b></li> </ul>
 <ul style="list-style-type: none"> <li>● When changing power connection is needed to correct the direction of rotation, be sure to turn off the power supply (earth leakage circuit breaker, etc.), and perform the work after making sure that the impeller has stopped completely. <b>Failure to do so may lead to electrical shock, short-circuit, or injury.</b></li> </ul> 	 <ul style="list-style-type: none"> <li>● When inspecting the mixer, be sure to turn off the power supply (earth leakage circuit breaker, etc.) so that the mixer may not start accidentally. <b>Failure to do so may lead to a serious accident.</b></li> </ul>
 <b>CAUTION</b>	
 <ul style="list-style-type: none"> <li>● Do not operate the product under any voltage other than described on the nameplate with the voltage variation limit within <math>\pm 5\%</math>. If it is operated with a generator, it is strongly suggested not to operate other equipment with the same generator. <b>Failure to observe this caution may cause malfunction and breakdown of the product, which may lead to electrical leakage or electrical shock.</b></li> </ul>	 <ul style="list-style-type: none"> <li>● Check that the motor rotates in the correct direction of rotation. Operating in the wrong direction may damage the mixer, which <b>may cause electrical leakage or electrical shock.</b></li> </ul>
 <ul style="list-style-type: none"> <li>● Do not use the product for hot or warm liquid over <math>40^{\circ}\text{C}</math>, as <b>doing so will damage the product, which may lead to electrical leakage or electrical shock.</b></li> </ul> 	 <ul style="list-style-type: none"> <li>● Do not use the product in a liquid other than water. <b>Use in oil, salt water or organic solvents will damage it, which may lead to electrical leakage or electrical shock.</b></li> </ul>
 <ul style="list-style-type: none"> <li>● When the product will not be used for an extended period, be sure to turn off the power supply (earth leakage circuit breaker, etc.). <b>Deterioration of the insulation may lead to electrical leakage, electrical shock, or fire.</b></li> </ul> 	 <ul style="list-style-type: none"> <li>● Do not touch the product with bare hands during or immediate after the operation, as the product may become very hot during operation. <b>Failure to observe this caution may lead to be burned.</b></li> </ul>
 <ul style="list-style-type: none"> <li>● Do not allow foreign objects (metal objects such as pins or wires) to enter the tank. <b>Failure to observe this caution could cause it to malfunction or to operate abnormally, which may lead to electrical leakage or electrical shock.</b></li> </ul>	



## PRECAUTIONS DURING MAINTENANCE AND INSPECTION

⚠ WARNING	
	<p>● Absolutely turn off the power supply before starting maintenance or inspection. Do not work with wet hands. <b>Failure to observe these cautions may lead to electrical shock or injury.</b></p>
	<p>● In case any abnormality (excessive vibration, unusual noise or odor) is found in the operation, turn the power off immediately and consult with the dealer where it was purchased or Tsurumi representative. <b>Continuing to operate the product under abnormal conditions may result in electrical shock, fire, or water leakage.</b></p>
 <b>WARNING</b>	
	<p>● After reassembly, always perform a test operation before resuming use of the product. <b>Improper assembly can result in electrical leakage, electrical shock, fire, or water leakage .</b></p>

## PRECAUTION TO POWER OUTAGE

⚠ WARNING	
	<p>● In case of power outage, turn off the power supply. <b>The product will resume operation when the power is restored, which presents serious danger to people in the vicinity.</b></p>
<p>power outage              OFF</p>	

## OTHER PRECAUTION

⚠ CAUTION	
	<p>● Never use the product for potable water. <b>It may present a danger to human health.</b></p>
<p>  Potable Water         </p>	

## 2 PART NAMES

### ■ Example

MR200

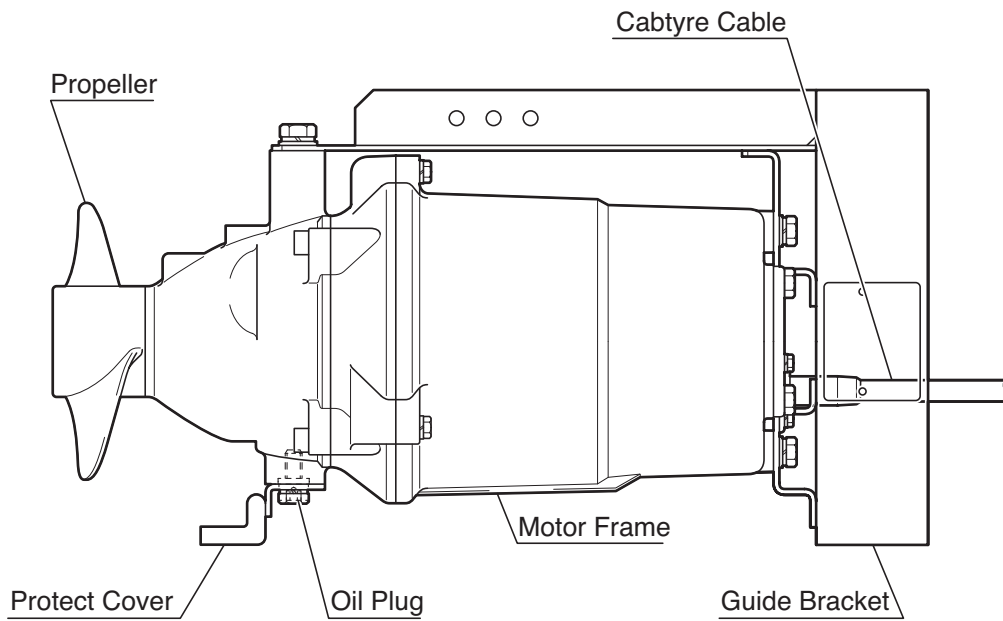

MR300

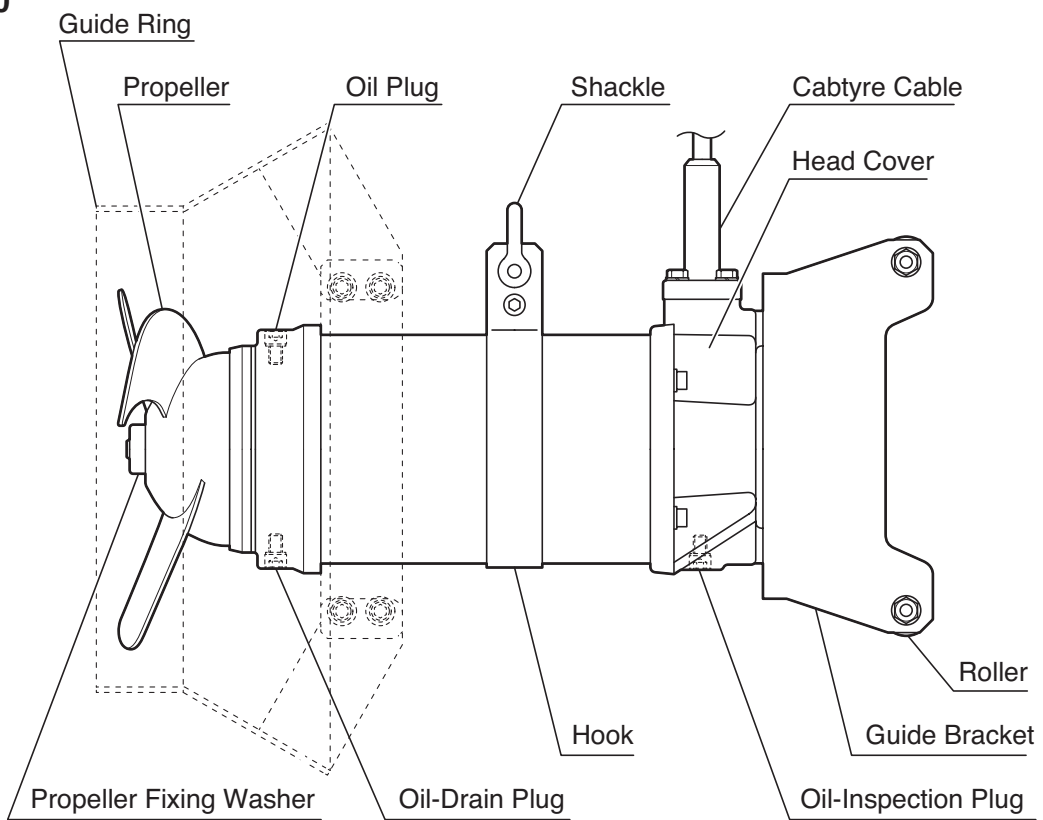

## MR400

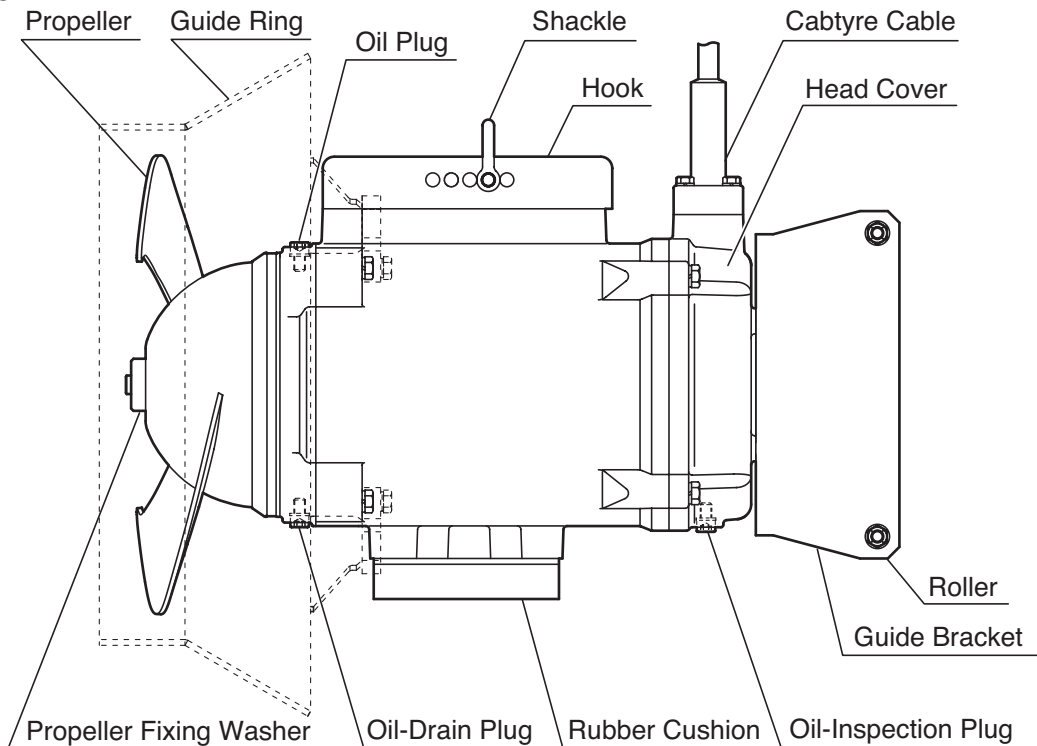

## 3 PRIOR TO OPERATION

After unpacking, verify the contents.

### Product Inspection

Inspect the product for damage during shipment, and make sure all bolts and nuts are tightened properly.

### Specification Check

Check the nameplate of the unit to verify that it is the product that you have ordered. Pay particular attention to its voltage and frequency specifications.

### Accessory Check

Verify that all accessory items are included in the package.

- Operation Manual .....1

**Note:** *If you discover any damage or discrepancy in the product, please contact the dealer where this equipment was purchased or the Tsurumi sales office in your area.*

### Mixer Models

Mixer are given the following model designations.

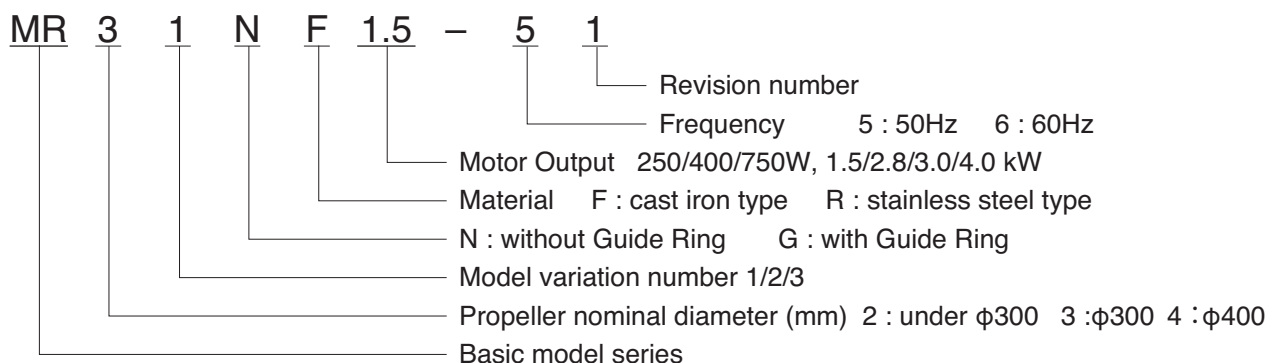

## Product Specifications



### CAUTION

- Do not operate this product under any conditions other than those that have been specified.
- To use an inverter in conjunction with this mixer. The motor's protector circuit must be prevented from tripping unintendedly. Please contact the dealer where this equipment was purchased or the Tsurumi sales office in your area for a unit that specifically accommodates the use of an inverter.

### Major Standard Specifications

Applicable Liquids	Property	Waste water ; 0 ~ 40°C
Mixer	Propeller	Two-blade propeller, three-blade propeller
	Shaft Seal	Double Mechanical Seal
	Bearing	Shielded Ball Bearing
Motor	Specifications	Dry Type Submersible Induction Motor, 4-Pole , 6-Pole , 8-Pole
	Insulation	Class E (750W max.), F (1.5kW minimum)
	Protection System (built-in)	Circle thermal protector (750W max.) Miniature protector (1.5kW minimum) Leak Sensor (Electrode) (1.5kW minimum)
	Lubricant	Turbine oil VG32 (non-additive)

### Standard Specifications Common to 50/60Hz

#### Without Guide Ring

Series	Model	Motor Output	Phase	Frequency	Starting Method	No. of Propeller Blades 50Hz/60Hz	Propeller Nominal Diameter mm	Weight
		kW						P
MR200	MR21NF 250	0.25	4	50/60	Direct-on-line	2	155/145	24
	MR21NF 400	0.4	4	50/60	Direct-on-line	2	185/155	24
	MR21NF 750	0.75	4	50/60	Direct-on-line	2	190/185	24
MR300	MR31N F/R 1.5	1.5	6	50/60	Direct-on-line	2/2	300	36
	MR32N F/R 1.5	1.5	6	50/60	Direct-on-line	2/2	300	36
	MR33N F/R 1.5	1.5	6	50	Direct-on-line	2	300	36
	MR31N F/R 2.8	2.8	6	50/60	Direct-on-line	3/2	300	46
	MR32N F/R 2.8	2.8	6	50/60	Direct-on-line	2/3	300	46
	MR33N F/R 2.8	2.8	6	50	Direct-on-line	3	300	46
MR400	MR41N F/R 3.0	3.0	8	50/60	Direct-on-line	2	400	112/122
	MR42N F/R 3.0	3.0	8	50/60	Direct-on-line	2	400	112/122
	MR43N F/R 3.0	3.0	8	50	Direct-on-line	2	400	112/122
	MR41N F/R 4.0	4.0	8	50/60	Direct-on-line	2	400	112/122
	MR42N F/R 4.0	4.0	8	50	Direct-on-line	2	400	112/122

#### With Guide Ring

Series	Model	Motor Output	Phase	Frequency	Starting Method	No. of Propeller Blades 50Hz/60Hz	Propeller Nominal Diameter mm	Weight
		kW						P
MR300	MR31G F/R 1.5	1.5	6	50/60	Direct-on-line	2/2	300	46
	MR32G F/R 1.5	1.5	6	50/60	Direct-on-line	2/2	300	46
	MR33G F/R 1.5	1.5	6	50	Direct-on-line	2	300	46
	MR31G F/R 2.8	2.8	6	50/60	Direct-on-line	3/2	300	56
	MR32G F/R 2.8	2.8	6	50/60	Direct-on-line	2/3	300	56
	MR33G F/R 2.8	2.8	6	50	Direct-on-line	3	300	56
MR400	MR41G F/R 3.0	3.0	8	50/60	Direct-on-line	2	400	125/135
	MR42G F/R 3.0	3.0	8	50/60	Direct-on-line	2	400	125/135
	MR43G F/R 3.0	3.0	8	50	Direct-on-line	2	400	125/135
	MR41G F/R 4.0	4.0	8	50/60	Direct-on-line	2	400	125/135
	MR42G F/R 4.0	4.0	8	50	Direct-on-line	2	400	125/135

**Note:** The weight(mass) indicated is the dry weight of the unit itself excluding the cable.



## 4 INSTALLATION

### CAUTION

- Do not use the mixer in liquids other than water, such as oil, salt water, or organic solvents.
- Use with a power supply voltage tolerance within  $\pm 5\%$  of the rated voltage.
- The water temperature for operating the mixer should be between  $0 \sim 40^{\circ}\text{C}$ . Failure to observe the precautions given above could cause the mixer to malfunction, which may lead to current leakage or electrical shock.

**Note:** To use the mixer for a special solution, contact the dealer where it was purchased, or the Tsurumi sales office in your area.

### Water depth limit

### CAUTION

Do not operate the mixer at a depth that exceeds the values given below.

Water depth limit	12 m
-------------------	------

### Preparation for Installation

Use a megger to measure the resistance between each core of the cabtyre cable and the (green) ground wire to verify the insulation resistance of the motor.

Insulation resistance reference value  
= 20M  $\Omega$  minimum

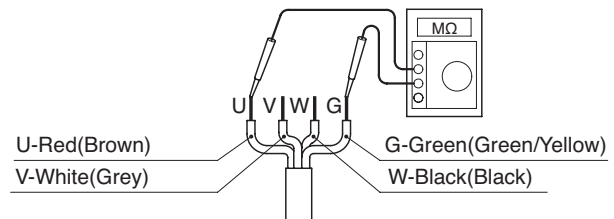

**Note:** The insulation resistance reference value of 20M  $\Omega$  minimum is based on a new or repaired mixer. For reference values of a mixer that has already been put into operation, refer to "8. Troubleshooting" of this manual.

### Precautions During Installation

### WARNING

When installing the mixer, be mindful of the mixer's center of gravity and weight. If the mixer is not suspended properly, the mixer may fall and break, which may lead to injury.

### CAUTION

When installing or moving the mixer, never suspend the mixer by the cabtyre cable. Doing so will damage the cable, which may cause a current leakage, electrical shock, or fire.

**Note:** Refer to the separate operation manual entitled "Lifting Equipment".

- (1) Check that the mixer is lifted in a horizontal posture. If the mixer is inclined, adjust the position of lifting fittings.
- (2) When transporting or installing the mixer, do not kink the cabtyre cable or use it in place of a rope.
- (3) Pull up slightly the cabtyre cable and the chain for installation of the lifting equipment, and fix them on the hook or the like. Bundle the excess portions of the cable and chain with cable ties or similar tools. (Prepare a hook in the opening.)

### CAUTION

Do not operate the mixer with the cabtyre cable dangling. Failure to observe this precaution may cause the cabtyre cable to become wrapped around the propeller, which could cut the cable, break the propeller, or cause flooding, which may lead to current leakage or electrical shock.

**Note:** When the mixer is submerged, bubbles are generated at the vicinity of the propeller. These bubbles come from air inside the propeller, and there is nothing wrong with it.

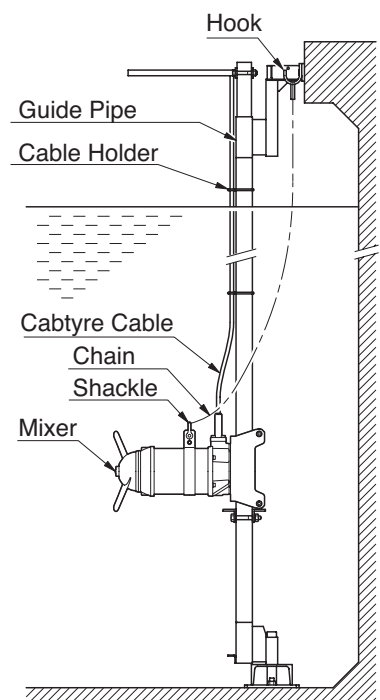



## Attaching a Chain to Suspend the Mixer

Refer to the illustration on the right in order to suspend the mixer by a chain.



### CAUTION

Make sure that the chain does not become twisted during installation. Failure to observe this precaution could cause the chain to break and the mixer to fall and break, which could lead to injury. When you mount shackles, be also careful so that the eye-bolt (pin) may not get dislocated, by means of providing a stainless steel wire or tying band.

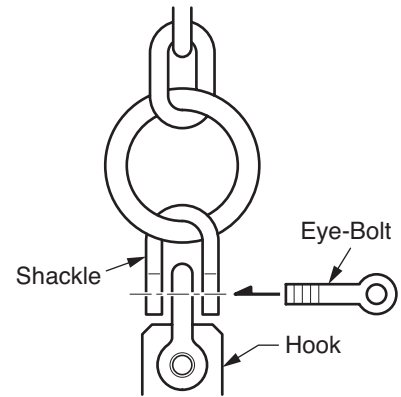

## 5

## ELECTRICAL WIRING

### Electrical Wiring Work



### WARNING

- All electrical work must be performed by an authorized electrician, in compliance with local electrical equipment standards and internal wiring codes. Never allow an unauthorized person to perform electrical work because it is not only against the law, but it can also be extremely dangerous.
- Improper wiring can lead to current leakage, electrical shock, or fire.
- Provide a circuit breaker and an overload protector exclusively for the product. Failure to do so could cause the product to malfunction and cause current leakage, which may lead to electrical shock.

Operate well within the capacity of the power supply and wiring.

### Grounding



### WARNING

Be sure to install the ground wire securely. Failure to observe this precaution could damage the mixer and cause current leakage, which may lead to electrical shock.



### CAUTION

Do not connect the ground wire to a gas pipe, water pipe, lightning rod, or telephone ground wire. Improper grounding could cause electrical shock.

### Connecting the Power Plug



### WARNING

Before inserting the power plug or connecting the wires to the terminal board, make sure that the power supply (i.e. circuit breaker) is properly disconnected. Failure to do so may lead to electrical shock, short, or injury caused by the unintended starting of the mixer.



### CAUTION

Do not use damaged cable cables, power plugs, or loose power outlets. Failure to observe this precaution could lead to electrical shock, short circuit, or fire.

Tighten the terminals at the end of the cable securely against the terminal board of the control panel, as illustrated below.



### CAUTION

When the mixer is equipped with wiring for the miniature protector and the leak sensor, it must be connected to a dedicated electric circuit. If the protection device is not connected, a trouble such as damage or submergence of the motor may be caused. For the dedicated electric circuit, consult with the dealer where this equipment was purchased or the Tsurumi sales office in your area.

Output 250W, 400W, 750W

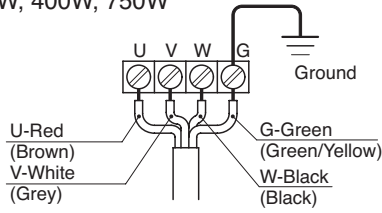

Output 1.5kW

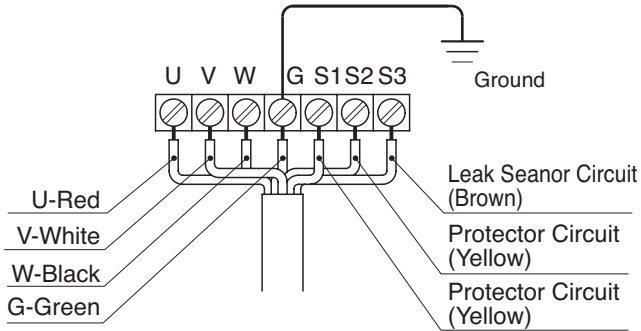

Direct-on-line starting (7c x 2mm<sup>2</sup> cable)

Output 2.8kW, 3.0kW, 4.0kW

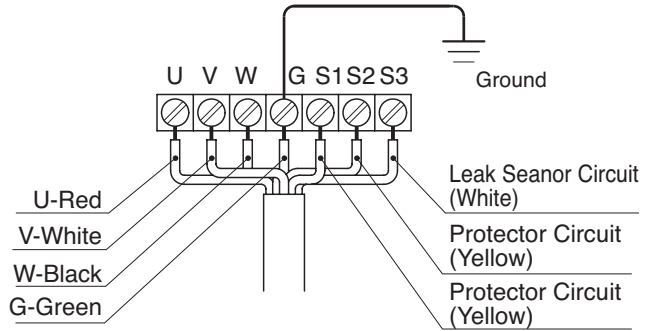

Direct-on-line starting (others)

## Wiring Diagram

Output 250W, 400W, 750W

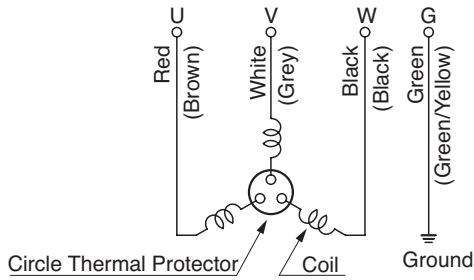

Output 1.5kW, 2.8kW

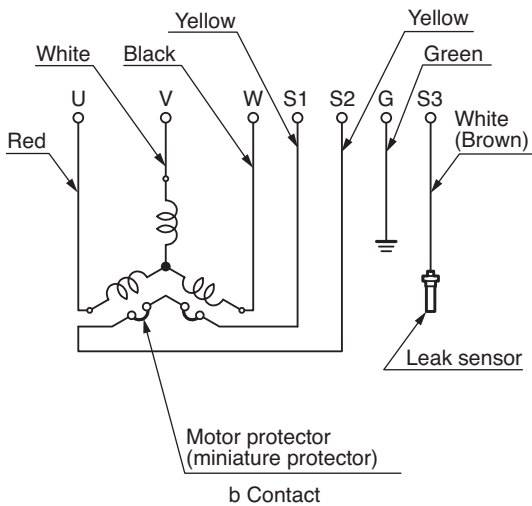

Output 3.0kW, 4.0kW

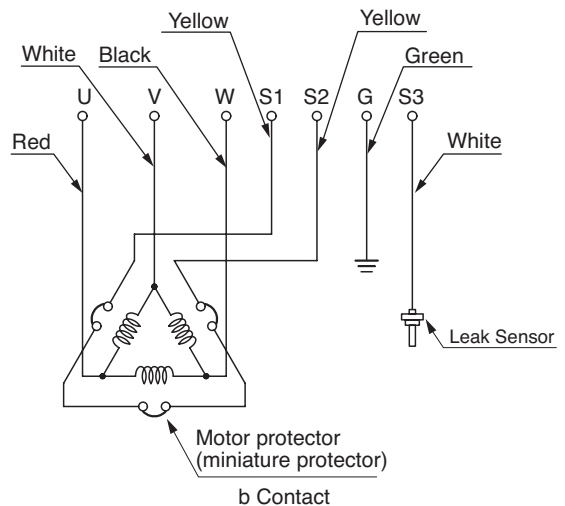

## Motor Protector

The mixer is equipped with an internal motor protector.

### 1. Circle Thermal Protector:

If a current overload or overheating occurs under the symptoms given below, the pump will stop automatically to protect the motor regardless of the water level at the time of operation. Because the motor protector is designed to cancel itself automatically if it trips to stop the pump, remove the cable from the terminal board and make sure to eliminate the cause of the problem, such as the following:

- Extreme fluctuation of power supply voltage
- Pump operated under overload condition
- Pump operated at open phase or binding condition

### 2. Miniature Protector

Embedded in the winding of the motor, the miniature protector is connected to a dedicated electric circuit in the external starting panel (including the control panel). The miniature protector's bimetal trips if the motor winding overheats. Upon receiving this signal, the external starting panel cuts off the electrical current to the motor. When the motor's temperature decreases, the bimetal automatically reverts and causes the external starting panel to restart the motor. Tsurumi's miniature protector adopts a "b" contact system in which the circuit "opens" when the protector trips (the circuit remains "closed" when normal).

**Note:** *Make sure to install a motor breaker or a thermal relay on the external starting panel to protect the motor from overload. The motor can be protected from overload, open phase, or reverse phase condition by installing a 3E relay.*

### 3. Leak Sensor

A mixer that is rated 1.5kW or more is provided with a water leak probe in the oil chamber.

If water leaks into the oil chamber due to wear of the mechanical seal, the water leak probe sends a signal to the dedicated circuit (prepared by the user) in the external starting panel or control panel and triggers a display, warning, and stop of the mixer to prevent the water from leaking into the motor.

**Note:** *If the motor protector trips to stop the mixer, make sure to eliminate the cause of the problem. Do not operate the mixer at an extremely low water level or with its propeller clogged with debris. Doing so will prevent the mixer from attaining its full potential and may also generate abnormal noise and vibration and cause damage to the mixer.*

## 6 OPERATION

### Prior to Operation

(1) Once again, check the nameplate of the mixer to verify that its voltage and frequency are correct.

**CAUTION** **Improper voltage and frequency of the power supply will prevent the mixer from attaining its full potential, and may also damage the mixer, which could lead to current leakage, electrical shock, fire, or water leakage.**

**Note:** *Verify the specs on the mixer's nameplate.*

(2) Check the wiring, power supply voltage, the capacity of the ground leakage circuit breaker, and the insulation resistance of the motor.

■ Insulation resistance reference value = 20MΩ minimum

**Note:** *The insulation resistance reference value of 20MΩ minimum is based on a new or repaired mixer. For reference values of a mixer that has already been put into operation, refer to "Maintenance and Inspection".*

(3) Adjust the setting of the thermal relay (i.e. 3E relay) to the mixer's rated current.

**Note:** *Verify the rated current on the mixer's nameplate.*

## Trial Operation



**WARNING** Never start the mixer that has not been inserted in the guide pipe and is still dangling. Doing so may cause a serious accident such as injury due to rotation of the propeller.



**CAUTION** Make sure to check the mixer's direction of rotation with the mixer exposed to atmosphere. Operating the mixer in reverse while it is submerged in water will damage the mixer, which may lead to current leakage and electrical shock.

- (1) Install the mixer to the guide pipe of the lifting equipment. Lower the mixer to the position where the rotating propeller does not contact with the water surface.
- (2) Operate the mixer momentarily (1 ~ 2 seconds) to check the direction of the rotation of the propeller. The propeller should rotate in the direction (counterclockwise as viewed facing the propeller) of the arrow on the rotation direction nameplate that is located on the motor frame.
- (3) To reverse the rotation, the following countermeasures must be taken.



**WARNING** Before changing the connections for reverse rotation, make sure that the power supply (i.e. circuit breaker) is properly disconnected and that the impeller has stopped completely. Failure to observe this may lead to electrical shock, short, or injury.

### COUNTERMEASURE

Direct-on-line starting

Interchange any two of the three wires designated U, V, and W, respectively.

**Note:** *This method cannot be used if the starting panel is equipped with a reverse-phase detector such as a 3E relay. If this is the case, contact the manufacturer of the starting panel, the dealer where the pump was purchased, or the Tsurumi sales office in your area.*

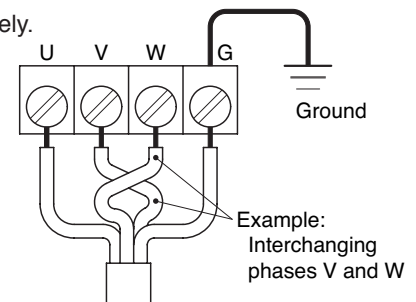

- (4) Immerse the mixer in water.
- (5) Operate the mixer for a short time (3 to 10 minutes) and perform the following checks:

Using an AC ammeter (clamp), measure the operating current at the phases U, V, and W that are connected to the terminal board.

### COUNTERMEASURE

Because an overload condition may be present at the mixer motor if the operating current exceeds the rated current, make sure to install the mixer securely and operate it at its proper rating.

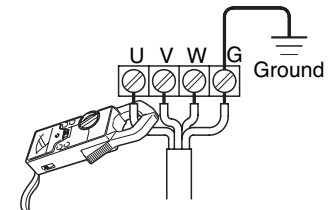

Using an AC voltmeter (tester), measure the voltage at the terminal board.

■ Power supply voltage tolerance = within  $\pm 5\%$  of the rated voltage

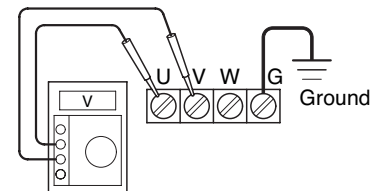

### COUNTERMEASURE

If the power supply voltage deviates from the variation value, the cause of the deviation may be the capacity of the power supply or the extension cable that is used. Refer to section "5. Electrical Wiring" to operate the mixer in the correct manner.



**CAUTION** In case the mixer exhibits an abnormal condition (such as a considerable amount of vibration, noise, or smell), disconnect the power supply immediately and contact the dealer where you purchased the equipment, or Tsurumi's sales office in your area. If the mixer continues to be used in the abnormal state, it may cause current leakage, electrical shock, or fire.

- (6) Proceed with the normal operation if no abnormal conditions are found during the trial operation.

## Operation

**WARNING** The mixer unit may be extremely hot during operation. To prevent burns, do not touch the mixer unit with bare hands during or after the operation.

**CAUTION**

- Do not start the mixer that is suspended by the lifting chain. Doing so may cause vibration, noise, and breakage of the chain. Be sure to install the mixer so that its mass is entirely borne by the stopper of the lifting equipment.
- Pull the cable and the lifting chain until there remains no slack, and fix them on the hook or the like above the tank.
- If the mixer is started with slack remaining on the cable or the lifting chain, they may get caught by the propeller resulting in cutting of the cable, breakage of the chain or the propeller, or a submergence accident.

Pay attention to the water level during the mixer operation. The mixer will become damaged if it is allowed to operate dry.

**Note:** Refer to the "Water Level During Operation" section.

Due to an overload operation or a mixer malfunction, if the motor protector trips to stop the mixer, make sure to eliminate the cause of the problem before restarting.

During the operation of the mixer, make sure that the number of times the mixer is started does not exceed the following limits: less than 10 times per hour on models with the output of 750W or less, 5 to 6 times per hour on models with the output of 1.5 to 4.0kW.

**Note:** A large amount of amperage flows when a submersible mixer is started, causing the temperature of its windings to rise rapidly. Beware that a frequent stop-and-go operation of the mixer will accelerate the deterioration of the insulation of the motor windings and thus affect the use life of the motor.

## Operating Water Level

Install the mixer by using the operating water level given below as reference.

**CAUTION** Do not operate the mixer below the operating water level, as doing so will damage the mixer, causing current leakage and electrical shock.

### Without Guide Ring

Unit:mm	
Model	H
MR21NF 250	300
MR21NF 400	300
MR21NF 750	300
MR31N F/R 1.5	500
MR32N F/R 1.5	500
MR33N F/R 1.5	500
MR31N F/R 2.8	500
MR32N F/R 2.8	500
MR33N F/R 2.8	500
MR41N F/R 3.0	700
MR42N F/R 3.0	700
MR43N F/R 3.0	700
MR41N F/R 4.0	700
MR42N F/R 4.0	700

### With Guide Ring

Unit:mm	
Model	H
MR31G F/R 1.5	700
MR32G F/R 1.5	700
MR33G F/R 1.5	700
MR31G F/R 2.8	700
MR32G F/R 2.8	700
MR33G F/R 2.8	700
MR41G F/R 3.0	900
MR42G F/R 3.0	900
MR43G F/R 3.0	900
MR41G F/R 4.0	900
MR42G F/R 4.0	900

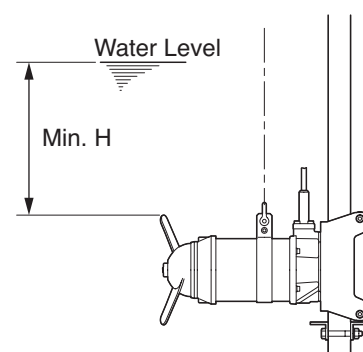

H: Operating Water Level

Even when using the operating water level shown above, swirls may emerge on the water surface depending on the tank shape or the installation position. In such a case, raise the water level.

# 7 MAINTENANCE AND INSPECTION

Regular maintenance and inspection are indispensable to maintaining the mixer's performance. If the mixer behaves differently from its normal operating condition, refer to section "8. Troubleshooting" on page 15 of this manual and take appropriate measures at an early stage. We also recommend that you have a spare mixer on hand for an emergency.

## Prior to Inspection



### WARNING

Make sure that the power supply (i.e. circuit breaker) is disconnected and disconnect the cable from the power outlet or remove it from the terminal board. Do not perform this operation with a wet hand. Failure to do so may cause electrical shock or unintended starting of the mixer, which may lead to serious accidents.

- (1) Pulling up the mixer  
Pull up the mixer to the ground using lifting equipment (a hoist or a chain block), and place it on a stable place. When using motorized lifting equipment, do not pull up the mixer at a time. Pull up the mixer while checking for catching. When rotational lifting equipment is used, return it to the position of 0 degree before pulling up the mixer. In particular, when extendable lifting equipment is used, interference between the mixer and the intermediate support located at the middle of the tank wall may hinder the pulling up operation.
- (2) Washing the Mixer  
Remove any debris attached to the mixer's outer surface, and wash the mixer with tap water. Pay particular attention to the propeller area, and completely remove any debris from the propeller.
- (3) Inspecting the Mixer Exterior  
Verify that there is no damage, and that the bolts and nuts have not loosened.  
If the paint has peeled, wash that area, allow the mixer to dry, and apply touch-up paint.

**Note:** *Touch-up paint must be provided by the user.*

*If the mixer must be disassembled for repair due to damage or loose bolts or nuts, contact the dealer where it was purchased, or the Tsurumi sales office in your area.*

## Daily and Periodic Inspection

Interval	Inspection Item
Weekly	Measuring the insulation resistance ■ Insulation resistance reference value = 1MΩ minimum [NOTE] The motor must be inspected if the insulation resistance is considerably lower than the last inspection. When voltage fluctuation occurs, the motor characteristics including the operating current does not conform to the rated value. Measuring the operating current ■ To be within the rated current Measuring the power voltage ■ Power supply voltage tolerance = within ± 5% of the rated voltage
Monthly	Inspecting the mixer ■ If the mixer's performance has diminished significantly, the propeller may be worn or the propeller may be clogged with debris. Remove any debris, and replace the part if it is worn.
Semi-yearly	Inspecting oil ■ 3,000 hours or 6 months, whichever comes first Inspection of lifting chain or rope ■ Replace if damage, corrosion, or wear has occurred to the chain or rope. Remove if foreign object is attaching to it.
Yearly	Changing oil ■ 6,000 hours or 12 months, whichever comes first [NOTE] Refer to section "Oil Inspection and Change Procedures" below for further detail. Changing the mechanical seal [NOTE] The inspection and replacement of the mechanical seal requires specialized equipment. To have this operation performed, contact the dealer where this equipment was purchased, or the Tsurumi sales office in your area.
Once every 2 years	Overhaul ■ The mixer must be overhauled even if the mixer appears normal during operation. Especially, the mixer may need to be overhauled earlier if it is used continuously. [NOTE] To overhaul the mixer, contact the dealer where it was purchased, or the Tsurumi sales office in your area.

**Note:** *In case the pumping liquid contains oil, paint, or slurry, it may cause the swelling of cable jacket or abrasion of the mechanical seal's sealing face, which will result in the mixer fault, it is strongly recommended to inspect earlier.*

## Storage

If the mixer will not be operated for a long period of time, pull the mixer up, wash the mixer, allow it to dry, and store it indoors.

**Note:** For reinstallation, be sure to perform a trial operation before putting the mixer into operation.

If the mixer remains immersed in water, operate it on a regular basis (i.e. once a week).

## Oil Inspection and Changing Procedures

The procedures for inspecting and changing the oil are given below.

### MR200

#### Inspecting Oil

Remove the oil plug and take out a small amount of oil. If the oil appears milky or intermixed with water, a likely cause is a defective shaft sealing device (i.e. mechanical seal), which requires that the mixer be disassembled and repaired.

#### Changing Oil

Remove the oil plug and drain the oil completely. Pour a specified volume of oil into the oil filler inlet.

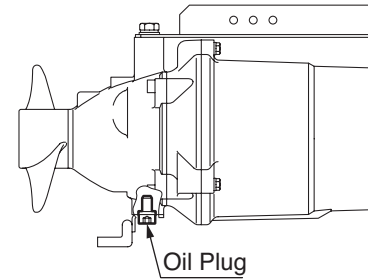

Unit : ml		
Model	Specified Oil	Specified Volume
MR200	Turbine Oil VG32 (non-additive)	380

### MR300/400

#### Inspecting Oil

Remove the oil-drain plug and take out a small amount of oil. If the oil appears milky or intermixed with water, a likely cause is a defective shaft sealing device (i.e. mechanical seal), which requires that the mixer be disassembled and repaired.

#### Changing Oil

Remove the oil plug and the oil-drain plug, and drain the oil completely. Pour a specified volume of oil into the oil filler inlet.

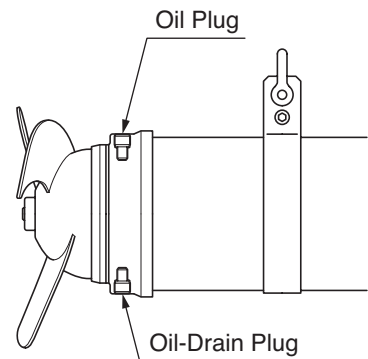

Unit : ml		
Model	Specified Oil	Specified Volume
MR300	Turbine Oil VG32 (non-additive)	540
MR400	Turbine Oil VG32 (non-additive)	1480

After long time operation, some of oil may enter the motor chamber.

This oil can be drained by removing the oil-inspection plug of the head cover (refer to "2. PART NAMES").

**Note:** The drained oil must be disposed of properly to prevent it from being released into the sewer or rivers. The packing or the O-ring for the oil plug must be replaced with a new part at each oil inspection and change.

## Maintenance

The parts listed below are dispensable items. Use the indicated replacement period as a rule of thumb for replacing these parts.

Part name	Replacement period
Mechanical Seal	When oil is discolored
Lubrication oil (turbine oil VG32)	Every 6,000 hours or 12 months, whichever comes first
Packing and O-ring	Each disassembly or inspection
V-ring	When the sealing lip is worn, and at each disassembly or inspection
Dust seal ring and Band	When worn



## 8 TROUBLESHOOTING



**WARNING** To prevent serious accidents, disconnect the power supply before inspecting the mixer.

Read this Operation Manual carefully before requesting repair. After re-inspecting the mixer, if it does not operate normally, contact the dealer where this equipment was purchased, or the Tsurumi sales office in your area.

Problem	Possible cause	Countermeasure
Mixer fails to start; or, starts but stops immediately.	(1) No proper power is supplied (i.e. power outage, voltage drop, etc.). (2) Malfunction in automatic control (control panel). (3) Foreign matter is wedged in the propeller, causing the motor protector to trip. (4) Open circuit in the cable. (5) Poor connection of the cable. (6) Voltage drop due to an overextension of the cable.	(1) Contact the electric power company or an electrical repair shop. (2) Have the cause investigated and repaired by a specialist. (3) Pull up the mixer unit and remove the debris. (4) Replace the cable. (5) Connect the cable correctly. (6) Shorten the extension cable or increase its size.
Mixer starts but stops after a certain length of time.	(1) The mixer has been operating for a long time while being exposed to air, causing the motor protector to trip. (2) Foreign matter is wedged in the propeller, causing the motor protector to trip.	(1) Operate the mixer deeper in the water or increase the volume of water. (2) Pull up the mixer unit and remove the debris.
The power supply circuit breaker trips.	(1) The equipment is not matched to the mixer specifications or the equipment's rating is set erroneously. (2) Malfunction of motor (seizure or water leakage). (3) A 50Hz unit is used at 60Hz.	(1) Replace the equipment with the correct specification or set it to the correct setting. (2) Repair or replace. (3) Check the nameplate and replace the mixer unit.
Low mixing performance.	(1) The motor rotates in reverse. (2) The propeller is worn. (3) A 60Hz unit is used at 50Hz. (4) The mixing load is high.	(1) Revert the motor to rotate in the proper direction. (2) Replace the propeller. (3) Check the nameplate and replace the mixer unit. (4) Change the mixer to a different model.
Mixer generates excessive noise or vibration.	(1) The support for the elevator is loose. (2) The bearing is worn. (3) The mixer is drawing in vortex or air. (4) Foreign matter is wedged in the propeller.	(1) Secure the support. (2) Have the cause investigated and repaired by a specialist. (3) Operate the mixer deeper in the water or increase the volume of water. (4) Pull up the mixer unit and remove the debris.

The following information is required when ordering repairs or making other inquiries.

Product model	
Manufacturing number	
Purchase date	
Remarks	

### Disposal of Product

Properly dispose of the product by disassembling it, presorting the contents, and sending them to the waste material treatment site.