

# **TRN Series**

## **Submersible Self-Aspiration Aerators**

### **OPERATION MANUAL**

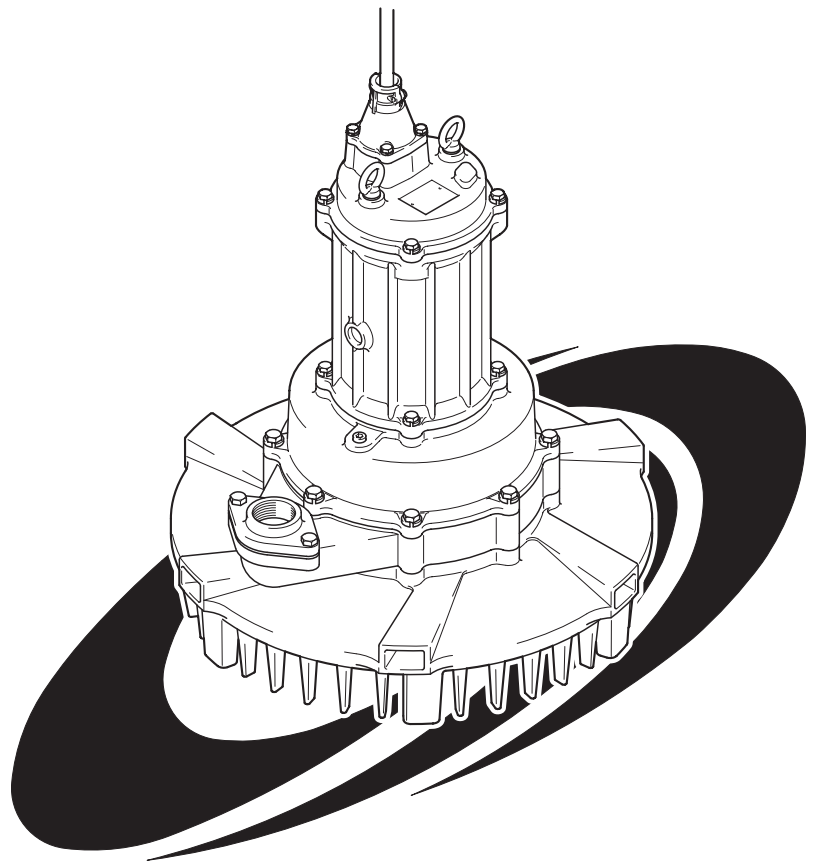

## INTRODUCTION

Thank you for selecting the Tsurumi TRN Series Submersible Self-Aspiration Aerators.

This operation manual explains the product operations and gives important precautions regarding its safe use. In order to use the product to maximum benefit, be sure to read the instructions thoroughly and follow them carefully.

To avoid accident, do not use the product in any way other than as described in this operation manual. Note that the manufacturer cannot be responsible for accidents arising because the product was not used as prescribed. After reading this operation manual, keep it nearby as a reference in case questions arise during use.

When lending this product to another party, always be sure to include this operation manual as well.

If this operation manual should become lost or damaged, ask your nearest dealer or Tsurumi representative for another copy.

Every effort has been made to ensure the completeness and accuracy of this document. Please contact your nearest dealer or Tsurumi representative if you notice any possible error or omission.

The contents of this document may not be copied in whole or in part without the express permission of Tsurumi Manufacturing Co., Ltd.

### CONTENTS

1. BE SURE TO READ FOR YOUR SAFETY .....	1
2. NAME OF PARTS .....	4
3. PRIOR TO OPERATION .....	4
4. INSTALLATION .....	6
5. ELECTRICAL WIRING .....	8
6. OPERATION.....	9
7. MAINTENANCE AND INSPECTION .....	13
8. DISASSEMBLY AND REASSEMBLY .....	14
9. TROUBLESHOOTING .....	17

# 1 BE SURE TO READ FOR YOUR SAFETY

Be sure to thoroughly read and understand the SAFETY PRECAUTIONS given in this section before using the equipment in order to operate the equipment correctly.

The precautionary measures described in this section are intended to prevent danger or damage to you or to others. The contents of this manual that could possibly be performed improperly are classified into two categories: **⚠ WARNING**, and **⚠ CAUTION**. The categories indicate the extent of possible damage or the urgency of the precaution. Note however, that what is included under **⚠ CAUTION** may at times lead to a more serious problem. In either case, the categories pertain to safety-related items, and as such, must be observed carefully.

- **⚠ WARNING** : Operating the equipment improperly by failing to observe this precaution may possibly lead to death or injury to humans.
- **⚠ CAUTION** : Operating the equipment improperly by failing to observe this precaution may possibly cause injury to humans and other physical damage.
- **NOTE** : Gives information that does not fall in the WARNING or CAUTION categories.
- **Explanation of Symbols:**



: The  $\triangle$  mark indicates a WARNING or CAUTION item. The symbol inside the mark describes the precaution in more detail ("electrical shock", in the case of the example on the left).



: The  $\circ$  mark indicates a prohibited action. The symbol inside the mark, or a notation in the vicinity of the mark describes the precaution in more detail ("disassembly prohibited", in the case of the example on the left).



: The  $\bullet$  mark indicates an action that must be taken, or instructs how to perform a task. The symbol inside the mark describes the precaution in more detail ("provide ground work", in the case of the example on the left).

## PRECAUTIONS TO THE PRODUCT SPECIFICATIONS

### ⚠ CAUTION













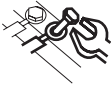
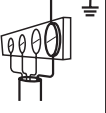

● Do not operate the product under any conditions other than those for which it is specified. **Failure to observe the precaution can lead to electrical leakage, electrical shock, fire, or other problems.**

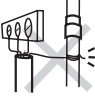















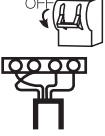



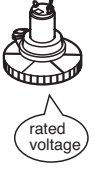

## PRECAUTIONS DURING TRANSPORT AND INSTALLATION

### ⚠ WARNING









	<p>● When transporting the product, pay close attention to its center of gravity and mass. Use an appropriate lifting equipment to lift the unit. <b>Improper lifting may result in the product damage, injury, or death.</b></p> 		<p>● Install the product properly in accordance with this operation manual. <b>Improper installation may result in electrical leakage, electrical shock, fire, or injury.</b></p> 
	<p>● Electrical wiring should be performed in accordance with all applicable regulations in your country. <b>Absolutely provide a dedicated earth leakage circuit breaker and a thermal overload relay suitable for the aerator (available on the market). Imperfect wiring or improper protective equipment can lead to electrical leakage, fire, or explosion in the worst case.</b></p> 		<p>● Provide a secure grounding dedicated for the aerator. Never fail to provide an earth leakage circuit breaker and a thermal overload relay in your starter or control panel (Both available on the market). <b>If an electrical leakage occurs due to a product failure, it may cause electrical shock.</b></p> 

 <b>CAUTION</b>			
	<p>● Provide a secure ground. Do not connect the grounding wire to a gas pipe, water pipe, lighting rod, or telephone ground line. <b>Improper grounding may lead to electrical shock.</b></p> 		<p>● Do not use the cable if it is found to be damaged. Connect the cable securely to the terminals. <b>Failure to observe this can lead to electrical shock, short-circuit, or fire.</b></p> 
	<p>● Do not scratch, fold, twist, make alterations, or bundle the cable, or use it as a lifting device. <b>The cable may be damaged, which may cause electrical leakage, short-circuit, electrical shock, or fire.</b></p> 		<p>● This aerator is neither dust-proof nor explosion-proof. Do not use it at a dusty place or at a place where corrosive, toxic or explosive gas presents or may be generated. <b>Use in such places could cause fire or explosion.</b></p> 
	<p>● When the product will be carried by hand, decide the number of persons considering the mass of the product. When lifting up the product, do not attempt to do it by simply bowing from the waist. Use the knees, too, <b>to protect your waist.</b></p>		

## PRECAUTIONS DURING TEST OPERATION AND OPERATION

 <b>WARNING</b>			
	<p>● Never start the aerator where people are present in the aeration tank. <b>If an electrical leakage occurs, it can cause electrical shock.</b></p> 		<p>● When changing power connection is needed to correct the direction of rotation, be sure to turn off the power supply (earth leakage circuit breaker, etc.), and perform the work after making sure that the impeller has stopped completely. <b>Failure to do so may lead to electrical shock, short-circuit, or injury.</b></p> 
	<p>● Never start the aerator while it is suspended, as <b>the unit may jerk and lead to injury.</b></p> 		
 <b>CAUTION</b>			
	<p>● Do not operate the aerator under any voltage other than described on the nameplate with the voltage tolerance limit within <math>\pm 5\%</math>. If it is operated with a generator, it is strongly suggested not to operate other equipment with the same generator. <b>Failure to observe this caution may cause malfunction and breakdown of the aerator, which may lead to electrical leakage or electrical shock.</b></p> 		<p>● Do not touch the product with bare hands during or after the operation, as the product may become very hot during operation. <b>Failure to observe this caution may lead to burn.</b></p> 
	<p>● Do not use the product in a liquid other than water. <b>Use in oil, salt water or organic solvents will damage it, which may lead to electrical leakage or electrical shock.</b></p> 		<p>● Do not run the product dry or operate it with its valve (air-inlet valve) closed, as <b>doing so will damage the product, which may lead to electrical leakage or electrical shock.</b></p> 
	<p>● Do not use the product in hot or warm liquid over <math>40^{\circ}\text{C}</math>, as <b>doing so will damage the product, which may lead to electrical leakage or electrical shock.</b></p> 		
	<p>● Do not allow foreign objects (metal objects such as pins or wires) to enter the suction inlet of the aerator. <b>Failure to observe this caution could cause it to malfunction or to operate abnormally, which may lead to electrical leakage or electrical shock.</b></p> 		<p>● When the aerator will not be used for an extended period, be sure to turn off the power supply (earth leakage circuit breaker, etc.). <b>Deterioration of the insulation may lead to electrical leakage, electrical shock, or fire.</b></p> 

## PRECAUTIONS DURING MAINTENANCE AND INSPECTION

⚠ WARNING	
	<p>● Absolutely turn off the power supply before starting maintenance or inspection. Do not work with wet hands. <b>Failure to observe these cautions may lead to electrical shock or injury.</b></p> 
	<p>● In case any abnormality (excessive vibration, unusual noise or odor) is found in the operation, turn the power off immediately and consult with the dealer where it was purchased or Tsurumi representative. <b>Continuing to operate the product under abnormal conditions may result in electrical shock or fire.</b></p> 
	
<p>● Do not disassemble or repair any parts other than those designated in the operation manual. If repairs are necessary in any other than the designated parts, consult with the dealer where it was purchased or Tsurumi representative. <b>Improper repairs can result in electrical leakage, electrical shock, or fire.</b></p> 	
⚠ CAUTION	
	<p>● After reassembly, always perform a test operation before resuming use of the product. <b>Improper assembly can result in electrical leakage, electrical shock, or fire.</b></p> 

## PRECAUTION TO POWER OUTAGE

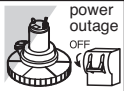
⚠ WARNING	
	<p>● In case of power outage, turn off the power supply. <b>The aerator will resume operation when the power is restored, which presents serious danger to people in the vicinity.</b></p> 

## 2 NAME OF PARTS

### Example

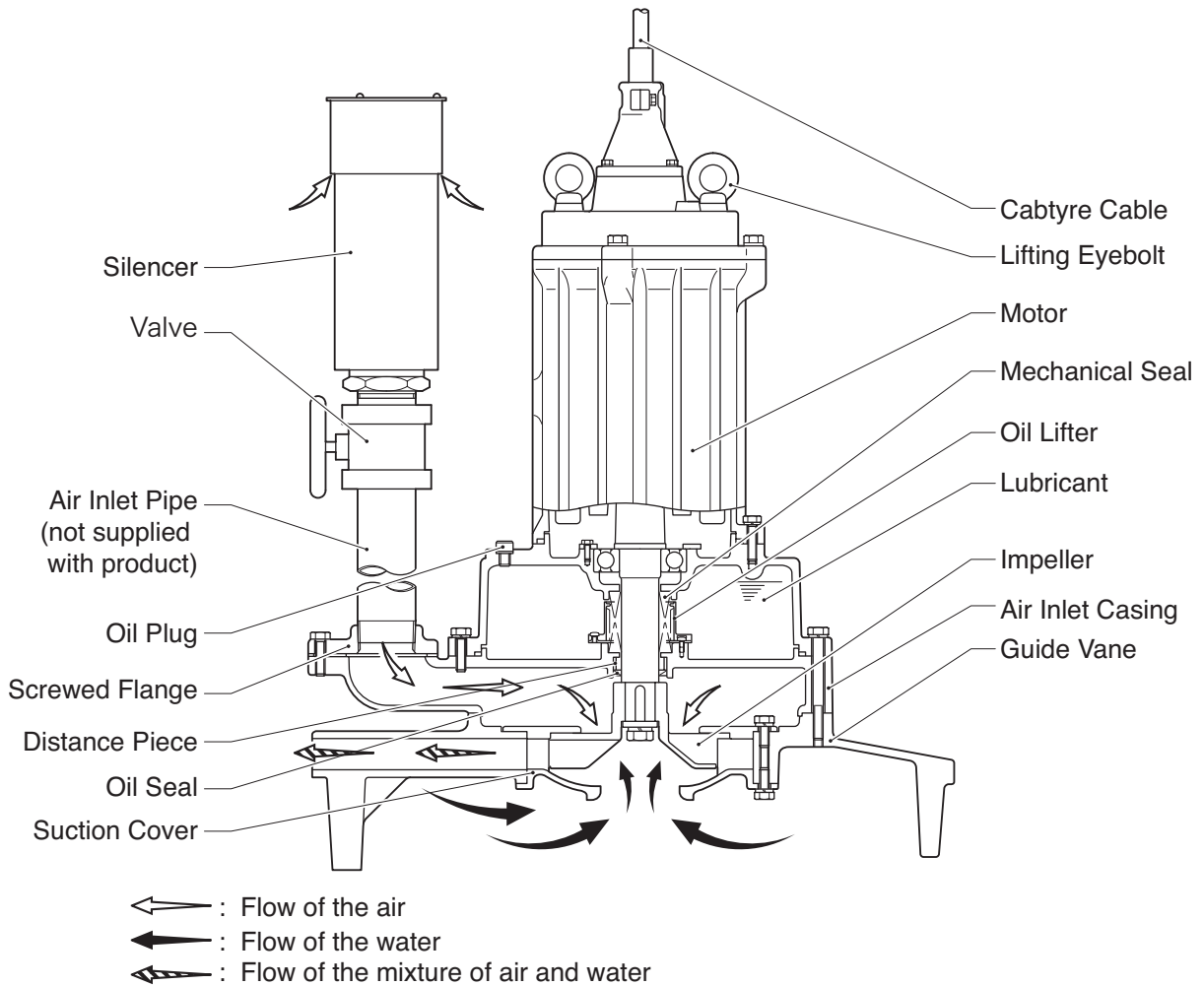

## 3 PRIOR TO OPERATION

When the unit is delivered, first perform the following checks.

### Inspection

While unpacking, inspect the product for damage during shipment, and make sure all bolts and nuts are tightened properly.

## Specification Check

Check the model number to make sure it is the product that was ordered. Be certain it is the correct voltage and frequency.

### Example of nameplate

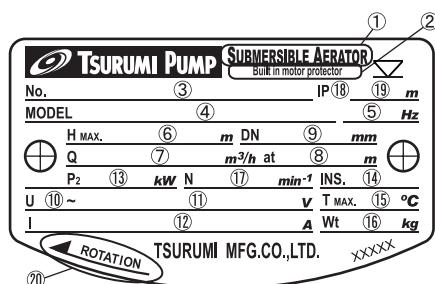
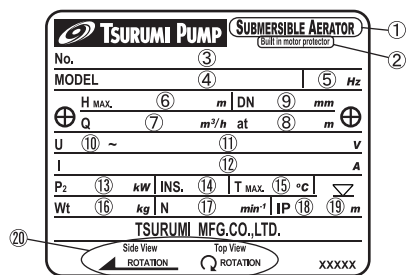

1	Submersible aerator	11	Rated voltage
2	Built in motor protector	12	Rated current
3	Serial number	13	Rated output power
4	Model	14	Insulation class
5	Frequency	15	Max. liquid temperature
6	Max. water depth (without compressor)	16	Weight without cable
		17	Speed of rotation
7	Air quantity	18	IP degree of protection
8	Operation depth	19	Max. immersion depth
9	Air inlet bore	20	Direction of rotation
10	Phase		

**Note:** If you discover any damage or discrepancy, please contact with the Tsurumi dealer from whom you purchased the product or the nearest Tsurumi representative office.

## Accessory Check

Verify that all accessory items are included in the package.

**Note:** If there is any problem with the product as shipped, contact your nearest dealer or Tsurumi representative at once.

## Product Specifications

**CAUTION** Do not operate this product under any conditions other than those for which it is specified. Failure to observe this precaution can lead to electrical shock, electrical leakage, fire, water leakage or other problems.

### Fluid to be Handled

Liquid to be Handled					Gas to be Handled (Suction through Air-inlet Pipe)
Type of Liquid	Temperature [°C]	pH	Chlorine Ion Concentration [mg/l]	Electrical Conductivity [μs/cm]	
Wastewater & sewage	0 to 40	5 to 9	Below 1,000	Below 1,000	should not be inflammable, corrosive, or toxic

### Major Standard Specifications

Aerator	Impeller	Semi-Open-Type
	Shaft Seal	Double Mechanical Seal
	Bearing	Shielded Ball Bearing
Motor	Specifications	Dry type Submersible Induction Motor, 2-Pole (1.5kW or less), 4-Pole (2.2kW or more)
	Insulation	Class F
	Protection System (built-in)	Circle thermal protector (7.5kW or less) Miniature Protector (12kW or more)
	Lubricant	Turbine oil VG32 (additive-free)

## ■ Standard specifications (50/60Hz)

Model	Air inlet Bore (mm)	Frequency (Hz)	Phase	Starting Method	Motor Output (kW)	Max. Water Depth (m)	Air Flow Rate at Max. Water Depth (m <sup>3</sup> /h)	Mass (Weight) (kg)
32TRN2.75	32	50/60	3	Direct-on-Line	0.75	3.5	7/8	55
32TRN21.5	32	50/60	3	Direct-on-Line	1.5	3.5	20/17	55
50TRN42.2	50	50/60	3	Direct-on-Line	2.2	3.6	39/38	140
50TRN43.7	50	50/60	3	Direct-on-Line	3.7	4	55/60	150
50TRN45.5	50	50/60	3	Direct-on-Line	5.5	4	78/79	150
80TRN47.5	80	50/60	3	Direct-on-Line	7.5	4.5	124/112	175
80TRN412	80	50/60	3	Star Delta	12	6	157/155	192
80TRN417	80	50/60	3	Star Delta	17	6	202/220	213
100TRN424	100	50/60	3	Star Delta	24	6	388/342	435
150TRN440	150	50/60	3	Star Delta	40	6	528/506	583

**Note:** *The air flow rates are expressed at the standard conditions; Temperature 20°C, 1atm.*

*The air flow rates may vary by up to approximately 5%.*

*The Maximum Water Depth (MWD) is the limit of installation depth that the aerator can operate without overload. If the aerator is installed and operates at a deeper position than this, the motor may be overloaded, and operation will be interrupted by the trip of the motor protector.*

*Mass (weight) excluding cable*

## 4 INSTALLATION



### CAUTION

- Do not use this product in liquids other than water, such as oil, salt water, or organic solvents.
- Use with a power supply voltage tolerance within  $\pm 5\%$  of the rated voltage.
- Do not use in water temperatures outside the range of 0 ~ 40°C, which can lead to failure, electrical leakage or shock.
- Use only in fully assembled state.

**Note:** *Consult your local dealer or Tsurumi representative before using with any liquids other than those indicated in this document.*

### Preparing for installation

Prepare a suitable chain or rope for the aerator. Refer to the weight of each aerator described in the table of "Standard specifications (50/60Hz)" on Page 6.

Before installing the product at a work site, you will need to have the following tools and instruments ready:

- Insulation resistance tester (megohmmeter)
- AC voltmeter
- AC ammeter (clamp-on type)
- Bolt and nut tighteners
- Power supply connection tools (screwdriver or box wrench)
- Cabling stakes (for use with cable and chain)

**Note:** *Please read also the instructions that come with each of the test instruments.  
Please use banding bands that is made of polypropylene.*



## Checks to make before installation

With the megohmmeter, measure the insulation resistance between each core lead and the ground lead (Green or Green/Yellow).

- Reference insulation resistance: 20MΩ or greater

**Note:** *The reference insulation resistance (20MΩ or greater) is the value when the product is new or has been repaired. For the reference value after installation, see below at Maintenance and Inspection(p. 13).*

## Precautions in installation



### WARNING

When installing the product, pay close attention to its center of gravity and weight. If it is not lowered into place correctly, it may fall and be damaged or cause injury.



### CAUTION

Do not under any circumstances install or move the product by suspending it from the cabtyre cable. The cable may be damaged, causing electrical leakage, shock, or fire.

Install the product at the work site, referring to the sample installation drawings on the next page and paying attention to the following precautions.

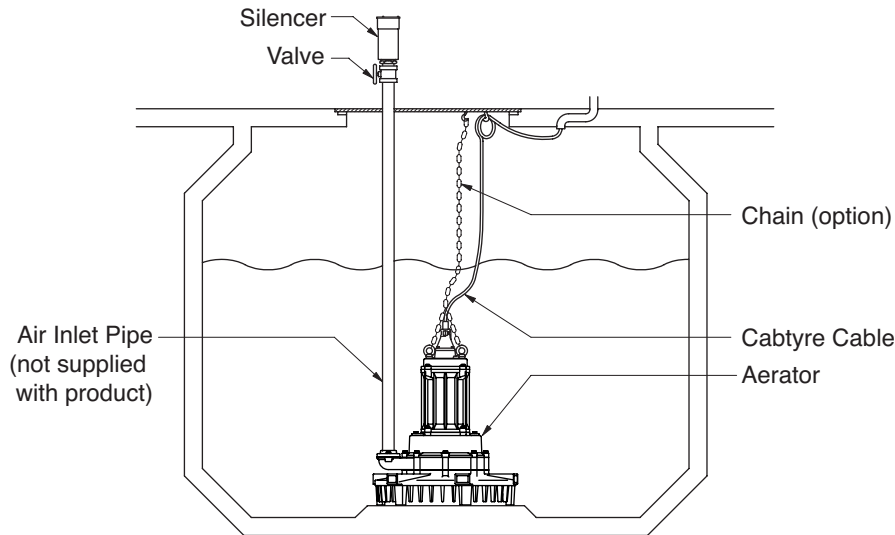

- (1) Avoid bending the cabtyre cable or using it as a rope when transporting or installing the product.
- (2) With the cabtyre cable and chain lightly raised, secure them to hooks (provided in the manhole or elsewhere).



### CAUTION

If the product is operated while the cable or chain is drooping, they may become caught in the impeller, causing the cable to be cut or the chain to break, damaging the impeller or causing water incursion to the product, which can result in electrical leakage or shock.



### CAUTION

In case you have to fix the cabtyre cable, the lifting chain, slacken it a little bit and fix on the chain taking a distance of about 1 meter in between (in order to reduce burdens on the cable). Be sure to protect the cable with plastic tapes or cloth-woven hoses in this case. Due to the vibrated water flow when the aerator is operated, the cabtyre cable may touch the corners in the tank and be broken. When cabtyre cable is used under such circumstances, protect it by wrapping it with vinyl tapes or cloth-woven hoses.

- (3) Install the air inlet pipe as vertical as possible. To minimize noise, use a PVC pipe or a braid-reinforced flexible hose, instead of a metal pipe.
- (4) Install the silencer well away from the liquid surface.  
In case that the aerator is used for the purpose of oxygen transfer, place the suction silencer at a place where fresh air presents.

- (5) It is recommended that the aerator be installed in a circular, polygonal, or square shape tank, as the aerator is designed to discharge the mixture of air-water in all directions. In case that a rectangular tank must be used, use a plural numbers of aerators that have a smaller Motor output.

## Attaching a lowering chain

When the product is lowered by a chain, attach as shown in the illustration.

- CAUTION** Make sure the chain does not become twisted. A twisted rope or chain may break, causing the product to drop and be damaged or cause injury. When you mount shackles, be also careful so that the eye-bolt (pin) may not get dislocated, by means of providing a stainless steel wire or tying band.

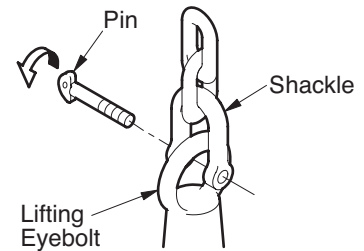

## 5 ELECTRICAL WIRING

### Performing electrical wiring

- WARNING**
- Electrical wiring should be performed by a qualified person in accord with all applicable regulations. Failure to observe this precaution not only risks breaking the law but is extremely dangerous.
  - Incorrect wiring can lead to electrical leakage, electrical shock or fire.
  - Absolutely provide a dedicated earth leakage circuit breaker and a thermal overload relay suitable for the aerator (available on the market). Failure to follow this warning can cause electrical shock or explosion when the product fails or an electrical leakage occurs.

Operate well within the capacity of the power supply and wiring.

### Grounding

- WARNING** Do not use the product without first grounding it properly. Failure to ground it can lead to electrical shock from an electrical leak or malfunction.

- CAUTION** Do not attach the grounding wire to a gas pipe, water pipe, lightning arrester or telephone grounding wire. Improper grounding can result in electrical shock.

### Connecting the power supply

- WARNING** Before connecting power supply wires to the terminals, make certain the power supply is turned off (circuit breaker, etc.), to avoid electrical shock, shorting, or unexpected starting of the product, leading to injury.

- CAUTION** Do not use the product with the cabtyre cable connected loosely, which can result in electric shock, shorting, or fire.

Connect the cabtyre cable leads to the terminals as shown, being careful not to let the leads become twisted together.

Direct-on-line Start (7.5kW or less)

Star-Delta Start (12kW or more)

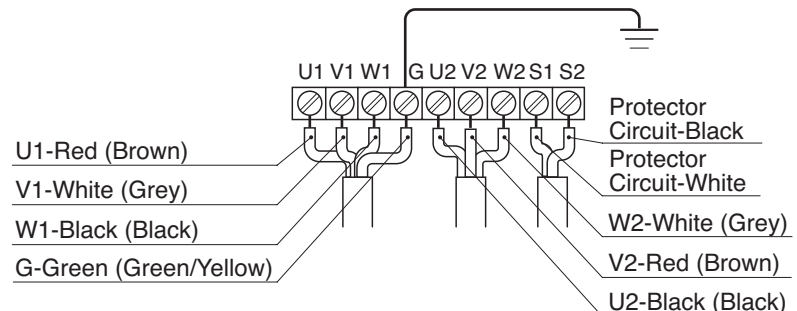
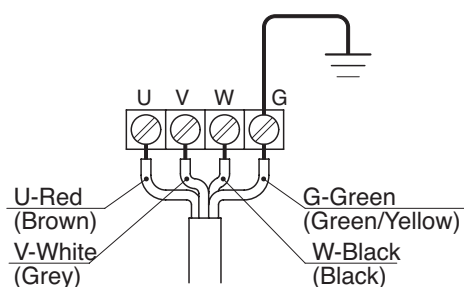

**Note:** The cabtyre cable, if it is unused, is terminally processed. If there is a need to peel off the cable again, have the terminal processed.

## ⚠ CAUTION

- If it is necessary to extend the cabtyre cable, use a core size equal to or larger than the original. This is necessary not only for avoiding a performance drop, but to prevent cable overheating which can result in fire, electrical leakage or electrical shock.
- If a cable with cut insulation or other damage is submerged in the water, there is a danger of water seeping into the motor causing a short. This may result in damage to the product, electrical leakage, electrical shock, or fire.
- Be careful not to let the cabtyre cable be cut or become twisted. This may result in damage to the product, electrical leakage, electrical shock, or fire.
- If it is necessary to submerge the connection leads of the cabtyre cable in water, first seal the leads completely in a molded protective sleeve, to prevent electrical leakage, electrical shock, or fire.

Do not allow the cabtyre cable leads to become wet.

Make sure the cable does not become excessively bent or twisted, and does not rub against a structure in a way that might damage it.

## Electrical Circuit Diagrams

Direct-on-line start (7.5kW or less)

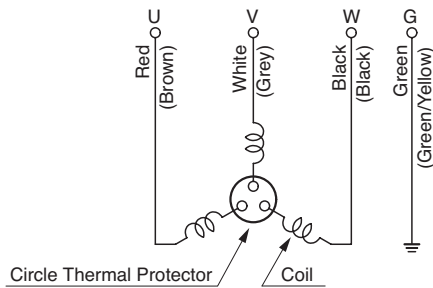

Star-Delta Start (12kW or more)

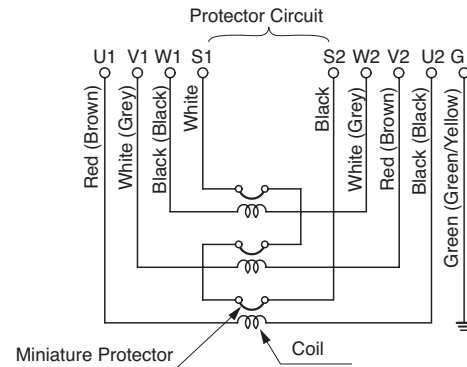

## 6 OPERATION

### Before starting

- (1) Check the model name plate to make sure once again that the product is of the correct voltage and frequency rating.

## ⚠ CAUTION

Using the product at other than rated voltage and frequency will not only lower its performance but may damage the product.

- (2) Confirm the wiring, supply voltage, circuit breaker capacity, and motor insulation resistance.

Reference insulation resistance = 20MΩ or greater

**Note:** The reference insulation resistance (20MΩ or greater) is the value when the product is new or has been repaired. For the reference value after installation, see below at Maintenance and Inspection (p.13)

- (3) The setting on the circuit breaker or other overload protector should be made in accord with the rated current of the product.

**Note:** See the model name plate on the product for its rated current.

## Test operation



### WARNING

- Never operate the product while it is suspended in the air. The recoil may result in injury or other major accident.
- Never start the product when people are standing next to it. An electrical leak can result in electrical shock.

(1) Run the product for a short time(1~2 seconds) to check the direction of rotation. The rotation is correct if the product recoil direction is counter-clockwise.



### CAUTION

Always perform the rotation check in air, not while the product is submerged. Running the product in reverse direction while submerged may damage the product, resulting in electrical leakage or electrical shock.

(2) If the direction is reversed, correct it using the countermeasure shown below.



### WARNING

Before changing the connections to correct the rotation, be sure to turn off the power supply (circuit breaker), and make sure the impeller has stopped completely, to avoid electrical shock or shorting.

#### COUNTERMEASURE

(Direct-on-line start models):

Interchange connections between any two of the three leads U, V, or W.

#### COUNTERMEASURE

(Star-delta start models):

Interchange connections between any two of the three leads R, S, or T.

**Note:** *You will not be able to solve it by this method if a phase detector like 3-E Relay is installed in your control panel. Consult with your dealer or supplier of the control panel.*

(3) Run the product for a short time (3~10minutes) and confirm the following.  
Using an ammeter(clamp-on type), measure the operating current at the U, V, and W phase leads on the terminals.  
Using an AC voltmeter(tester), measure voltage at the terminals.  
Supply voltage tolerance: within  $\pm 5\%$  of rated voltage.

#### COUNTERMEASURE

If the operating current exceeds the rated value, motor overload may be a cause. Make sure the product has been installed under proper conditions as described in the section on Installation(p.6)

#### COUNTERMEASURE

If the supply voltage is outside the tolerance, possible causes are the power supply capacity or an inadequate extension cable. Look again at the section on Electrical Wiring(p.8) and make sure the conditions are proper.



### CAUTION

In case of very excessive vibration, unusual noise or odor, turn off the power immediately and consult with your nearest dealer or Tsurumi representative. Continuing to operate the product under abnormal conditions may result in electrical shock, fire, or electrical leakage.

## Operation



### WARNING

- The product may become very hot during operation. Be careful not to contact it accidentally to avoid being burned.
- When the product is not used for an extended period, be sure to turn off the power (circuit breaker, etc.). Deterioration of the insulation may lead to electrical leakage, electrical shock, or fire.
- In case of a power outage, turn off the power to the product to avoid having it start unexpectedly when the power is restored, presenting serious danger to people in the vicinity.

Make sure the silencer and valve are fully open.

If the air flow rate must be adjusted, do so by adjusting the valve opening.

**Note:** *When the valve is squeezed, the load to the motor will increase. Make sure that the running current does not exceed the rated current of the aerator.*

If the motor protection system operates due to an overload or malfunction, causing the product to stop, first investigate and remove the cause before restarting.

**Note:** *When you operate this aerator, number of starts should be maximum 5 to 6 times per hour for the models of up to 3.7kW, 3 to 4 times per hour for the models of 5.5 to 17kW, and 2 to 3 times per hour for the models of 24kW or over.*

*In order to protect the motor, avoid to make turn-on and turn-off operations frequently within short time.*

*A large amount of current flows when the aerator is started, causing the temperature of its windings to rise rapidly. Beware that frequent on-and-off operations will accelerate the deterioration of motor windings affecting the life of the motor.*

## Maximum water depth (Water depth limit)



### CAUTION

Do not operate the product at a depth greater than the designated limit, which can cause the unit to malfunction, resulting in electrical leakage or shock.

Model	Maximum Water Depth (m)
32TRN2.75	3.5
32TRN21.5	3.5
50TRN42.2	3.6
50TRN43.7	4
50TRN45.5	4
80TRN47.5	4.5
80TRN412	6
80TRN417	6
100TRN424	6
150TRN440	6

## Motor protection system

The products have a built-in motor protection system.

### 1. Circle Thermal Protector (7.5kW or less)

If an excessive current is detected or the motor overheats, for reasons such as the following, the pump will automatically stop operating regardless of the water level, to protect the motor.

- Change in supply voltage polarity
- Overload
- Open-phase operation or operation under constraint



### WARNING

If repair or maintenance is attempted with cables connected to power supply, unintended automatic restarting of the motor may cause human injury.

### 2. Miniature Protector (12kW or more)

This protector is embedded inside the motor coil. If the coil should overheat for any reason, bending of the bimetal of the miniature protector triggers a signal, which in turn causes a dedicated circuit in the additionally provided starting console or control panel to shut off the motor current. When the temperature returns to normal, the protector is automatically reset, but restarting is controlled from the starting console or control panel.

**Note:** *A b-contact miniature protector is adopted, which is normally "closed" and goes to "open" upon overheating. To protect the motor from current surges, be sure to install a motor breaker thermal relay or similar device in the external starting console or control panel. A 3E relay is able to protect the motor from overload, open-phase or reverse-phase operation.*

**Note:** *Always determine the cause of the problem and resolve it before resuming operation. Simply repeating cycles of stopping and restarting will end up damaging the product. Do not continue operation at very low lift, low water level, or while the strainer is clogged with debris. Not only will performance suffer, but such conditions may cause noise, heavy vibration, and malfunctioning.*

## NOISE

Suction noise will be generated at the suction silencer while the gas to be handled is being sucked by the submersible aerator. The following table shows the sound pressure level of each aerator. Note that these sound pressure level data are those measured at an indoor test facility in our factory and are not the guaranteed figures that are expected at your site. Also note that the sound pressure level may vary depending on various factors like piping condition.

### Measured Sound Pressure Level Data

Air inlet Bore (mm)	Model	Moter Output (kW)	Installation Water Depth h [m]	A-weighted Sound Pressure Level [dB(A)]	Back Ground Noise Level [dB(A)]
32	32TRN2.75	0.75	1.5	53	43
			3.5	54	
	32TRN21.5	1.5	1.5	53	43
			3.5	58	
50	50TRN42.2	2.2	2.5	61	43
			3.6	61	
	50TRN43.7	3.7	2	66	43
			4	70	
	50TRN45.5	5.5	2	69	43
			4	70	
80	80TRN47.5	7.5	2	71	42
			4.5	68	
	80TRN412	12	3	72	42
			6	73	
	80TRN417	17	3	74	45
			6	72	
100	100TRN424	24	4.5	73	45
			6	74	
150	150TRN440	40	3.5	70	49
			6	74	

- Note:**
- Measurements of the sound pressure level have been carried out in accordance with JIS B 8346-1991, "Fans, Blowers and Compressors - Determination of A-weighted Sound Pressure Level".
  - The equipment used for the measurement was a standard sound level meter that complies with JIS C 1502.
  - Frequency correction "A" and "SLOW" time weighting were used for the sound level meter.
  - The sound pressure level data are those that have been calculated from the average sound pressure levels measured at four (4) points, all of which are located at the same height of 1.6m from the floor but are equally distributed to four-way to the distance of 1m away from the silencer.
  - PVC Braid-reinforced flexible hoses of 10m long were used as the air-inlet pipe.

# 7 MAINTENANCE AND INSPECTION

Regular maintenance and inspections are a necessity for continued efficient functioning of the product. If any abnormal conditions are noticed, refer to the section on Troubleshooting (p.17) and take corrective measures immediately. It is recommended that a spare unit be kept ready in case of any problems.

## Prior to inspection

**WARNING** Detach the cable from the terminals, after making certain the power supply (circuit breaker, etc.) is turned off. Do not work with wet hands. Failure to follow these precautions may result in a serious accident from electrical shock or unexpected starting of the motor.

- (1) Washing  
Remove accumulated matter from the surface of the unit and wash it with clean water. Take special care to remove any debris from the impeller and the suction cover.
- (2) Inspecting the exterior  
Look for any peeling or chipped paint, and make sure the nuts and bolts are fastened securely. Any cracks in the surface should be repaired by cleaning that area, drying it and then applying a touchup coating.

**Note:** Touchup is not supplied. Some kinds of damage or looseness may require that the unit be disassembled for repairs. Please consult with your nearest dealer or Tsurumi representative.

## Regular Inspection

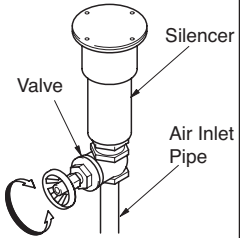
Interval	Inspection Item
Every Day	<ul style="list-style-type: none"> <li>■ Measure operating current ● To be below the rated current.</li> <li>■ Measure power voltage ● Power supply voltage tolerance (within ±5% of the rated voltage)</li> </ul>
Monthly	<ul style="list-style-type: none"> <li>■ Measure insulation resistance ● Reference insulation resistance = 1MΩ or greater <i>Note: If the insulation resistance has become notably lower than the previous inspection, an inspection of the motor will be necessary.</i></li> <li>■ Aerator inspection ● A noticeable drop in performance may indicate wear in the impeller, suction cover, etc., or else clogging of the strainer stand, etc. Remove the clogged debris, and replace any worn parts.</li> <li>■ Air inlet system check ● If performance drops significantly, check for blockage of the air inlet pipe, and for damage to the submerged part of the pipe that might cause water to leak into the pipe. Check for clogging of the silencer, and wash if necessary.</li> </ul> 
Half-yearly	<ul style="list-style-type: none"> <li>■ Inspection of lifting chain or rope ● Replace if damage, corrosion, or wear has occurred to the chain or the rope. Remove if foreign object is attaching to it.</li> </ul>
Yearly	<ul style="list-style-type: none"> <li>■ Oil inspection ● Check the oil every 12 months or after 6,000 hours of use, whichever comes first. <i>Note: Refer to details of oil inspection and oil change (p.14)</i></li> </ul>
Every 2 years	<ul style="list-style-type: none"> <li>■ Change oil ● Change the oil every 24 months or after 9,000 hours of use, whichever comes first.</li> <li>■ Designated oil : Turbine Oil VG32 (Additive -free) <i>Note: Refer to details of oil inspection and oil change (p.14)</i></li> <li>■ Change mechanical seal <i>Note: Specialized know-how is required for inspecting and replacing the mechanical seal. Consult with your nearest dealer or Tsurumi representative.</i></li> </ul>
Every 2 to 5 years	<ul style="list-style-type: none"> <li>■ Overhaul ● This should be carried out even if there are no problems with the product. The frequency depends on how continuously the product is in use. <i>Note: Consult with your nearest dealer or Tsurumi representative.</i></li> </ul>

**Note:** In case the pumping liquid contains oil, paint, or slurry, it may cause the swelling of cable jacket or abrasion of the mechanical seal's sealing face, which will result in the pump fault, it is strongly recommended to inspect earlier.

## Storage

When the unit is out of use for an extended period, wash it and dry it thoroughly, then store it indoors.

**Note:** *Always run a test operation before putting the unit back into service.*

If the unit is left in the water, it should be run at a minimum of once a week.

## Oil inspection and Oil change

### Inspecting Oil

Remove the oil plug and tilt the unit to drain a small amount of oil. If the oil is milky white or has water mixed in with it, the mechanical seal may be faulty. In this case the unit will need to be disassembled and repaired.

### Replacing Oil

Remove the oil plug and drain all the oil, then replace it with the specified amount of oil as shown in the table.

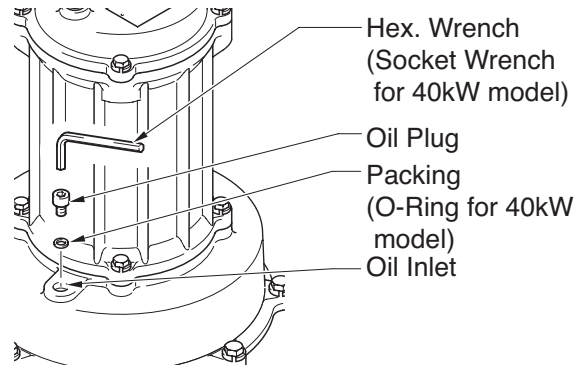

**Note:** *Worn oil and other waste products should be disposed of by a qualified agent, in accord with applicable laws. The oil plug packing and O-ring should be replaced each time the oil is inspected or changed.*

Model	Oil Quantity (ml)
32TRN2.75 , 32TRN21.5	1,400
50TRN42.2 , 50TRN43.7	5,100
50TRN45.5	6,000
80TRN47.5 , 80TRN412	
80TRN417	10,000
100TRN424	
150TRN440	16,000

## Replacement Parts

The table lists the parts that need to be replaced periodically. Replace these using the recommended frequency as a guideline.

Part	Recommended Frequency
Mechanical Seal	When oil becomes milky.
Oil (Turbine Oil VG 32 (Additive -free) )	Every 24 months or after 9,000 hours of use, whichever comes first.
Packing, O-Ring	Each time unit is disassembled or inspected
Oil Seal	When lip is worn, and each time unit is disassembled or inspected
Distance Piece	When it is worn or torn.

## 8 DISASSEMBLY AND REASSEMBLY

### ⚠ WARNING

- **Before disassembling the unit, first detach the cabtyre cable from the terminals, after making certain the power supply (circuit breaker, etc.) is turned off. To avoid electrical shock, do not work with wet hands. Never check the operation of any parts (impeller rotation, etc.) by turning on the power while the unit is partially assembled. Failure to observe these precautions may result in serious accident.**
- **Do not disassemble or repair any parts other than those designated here. If repairs are necessary in any other than the designated parts, consult with your nearest dealer or Tsurumi representative. Improper repairs can result in electrical leakage, electrical shock, fire, or water leaks.**
- **After reassembly, always perform a test operation before resuming use of the product. Improper assembly will cause the product to malfunction, resulting in electrical shock or water leaks.**

The procedure for disassembly and reassembly is shown here to the extent necessary for impeller replacement. A specialized know-how is necessary for work in the mechanical seal and the motor parts. Contact your nearest dealer or Tsurumi representative in the event such repairs are necessary.



## Disassembly

**Note:** Always remove the oil before proceeding with disassembly.

**Note:** Put a tally mark on the mating surface of each component. This will be an alignment guide in the re-assembly process. Be sure to keep the disassembled parts, paying attention not to lose any of them.

(1) Remove the suction cover.

Remove the hex. bolts (hex. nuts for 24 and 40kW) and spring washers, then remove the suction cover and suction cover packing from the guide vane.

(2) Remove the impeller.

With a box spanner or the like, remove the hex. bolt, spring washer and impeller washer, then remove the impeller and impeller adjusting washer.

(3) Remove the guide vane

Be sure to identify the bolts that shall be unfastened, referring to the "Exploded View" on page 16.

0.75 and 1.5kW

Remove the 3 bolts among the 6 bolts on the air passage (casing). Refer to the figure on the right.

2.2kW and above

Remove 4 bolts among the 8 bolts. Refer to the "Exploded View" on page 16.

Remove the bolts, spring washers, and then remove the guide vane from the air passage.

0.75kW & 1.5kW

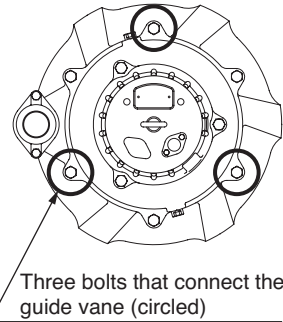

**Note:** If you incorrectly unfastened other bolt than instructed above, this might have impaired the sealing effect of the shaft seal (mechanical seal). Consult your dealer or Tsurumi representative for the re-assembly of this part, as it is required to test the sealing effect using a vacuum system.

(4) Remove the middle plate (2.2kW or above only)

2.2kW to 5.5kW

Remove the hex. bolts and spring washers, then remove middle plate.

7.5kW and above

Remove the hex. socket cap bolts, and then remove the middle plate.

A loosening preventing adhesive will come out in a white powder attaching to the bolts. Clean with a suitable brush.



**CAUTION** A worn Impeller may have sharp edges that can cause injury, and should be handled with care.

## Reassembly

Reassembly can be performed by reversing the steps for disassembly, paying attention to the following precautions.

**Note:** After reassembly, be sure to full with the required amount of oil. Replace all the packing and O-ring with new, and replace any other worn or damaged parts.

**Note:** Re-assemble every component confirming the direction and the tally marks. Make sure that there is no component remaining unassembled.

**Note:** For 7.5kW model or above, apply "LOCTITE 243" (commercially available) to three (3) threads of each bolt of the middle plate for the purpose of preventing loosening of the bolts, then fasten the bolts with the suitable torque, 17.7N·m for 7.5 kW through 24kW and 30.9N·m for 40 kW models.

**Note:** Adjust the clearance between the middle plate and the impeller by increasing or reducing the impeller adjusting washer. (Recommended clearance for 17kW model or below is less than 0.5mm, and for 24kW model or over is less than 0.8mm.)

After attaching the impeller, and again attaching the suction cover, check to make sure the impeller rotates smoothly and that it does not rub against the suction cover and middle plate. In case the impeller rubs against the suction cover and middle plate, add the impeller adjusting washer and suction cover packing in order to adjust.

# Exploded View

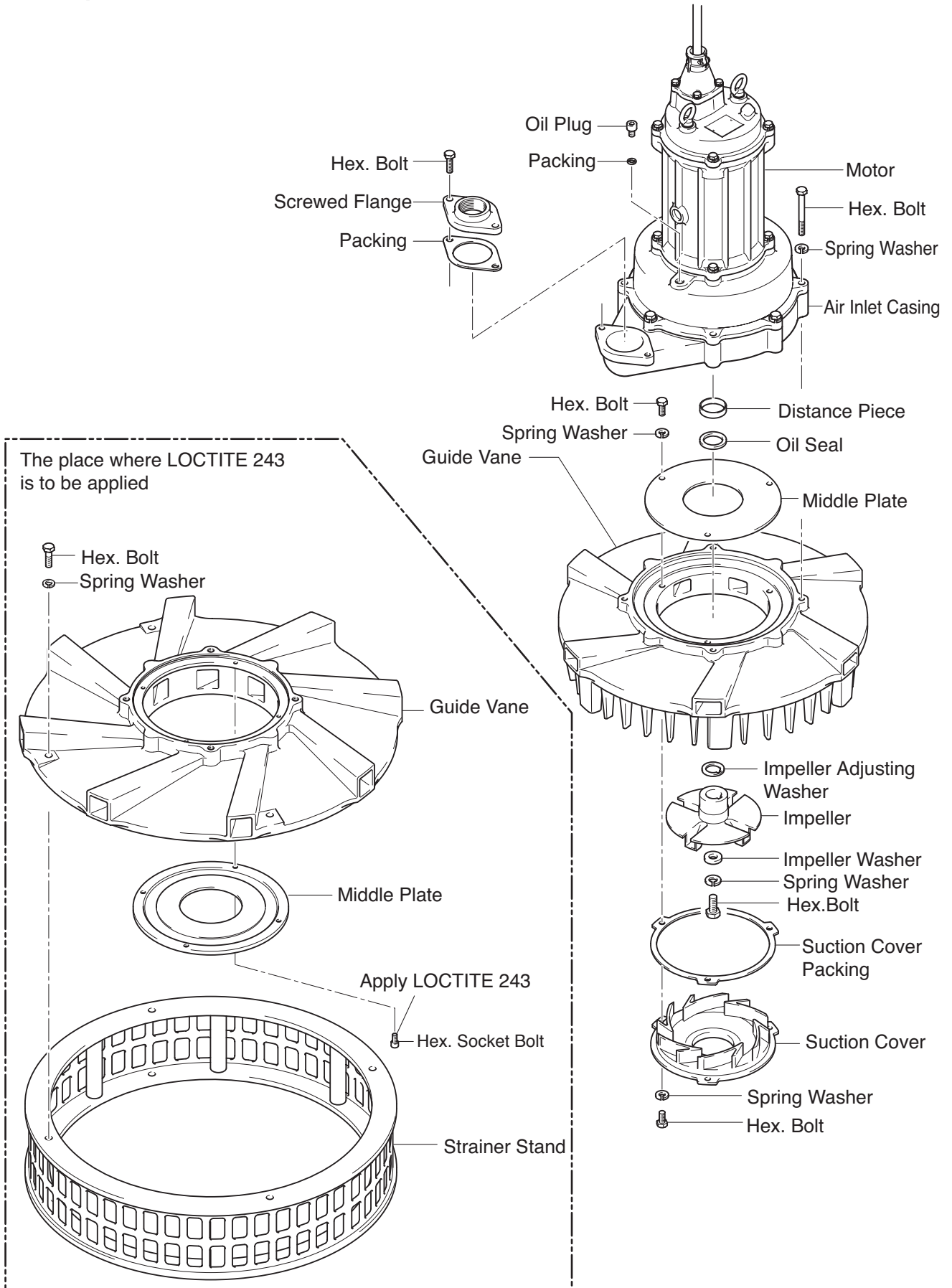

**Note:** The above disassembling block diagram is a typical one, and there may be some differences from actual shapes or compositions depending on models.

# 9 TROUBLESHOOTING

**⚠ WARNING** Always turn off the power before inspecting the unit. Failure to observe this precaution can result in serious accident.

Before ordering repairs, carefully read through this operation manual, then repeat the inspection. If the problem remains, contact your nearest dealer or Tsurumi representative.

Problem	Possible cause	Countermeasure
Aerator fails to start	<ul style="list-style-type: none"> <li>① No power supply (power outage, etc.)</li> <li>② Disconnection or inadequate connection of cabtyre cable</li> <li>③ Foreign object lodging on impeller</li> <li>④ Low voltage or voltage drop</li> </ul>	<ul style="list-style-type: none"> <li>① Contact the power company or an electrical repair shop.</li> <li>② Check if the cabtyre cable or wiring is disconnected.</li> <li>③ Check and remove any debris.</li> <li>④ Provide the rated voltage, or make sure the cabtyre cable extension is the proper standard.</li> </ul>
Stops soon after starting	<ul style="list-style-type: none"> <li>① Too much water depth</li> <li>② Foreign object lodging on impeller</li> <li>③ Impeller rubs against middle plate.</li> <li>④ Impeller rubs against suction cover.</li> <li>⑤ A 50Hz product is used at 60Hz.</li> <li>⑥ Air inlet pipe or silencer is obstructed.</li> <li>⑦ Valve is too much squeezed.</li> <li>⑧ Motor error (burn, water incursion, etc.)</li> </ul>	<ul style="list-style-type: none"> <li>① Make the water depth less than specified.</li> <li>② Check and remove any debris.</li> <li>③ Add the impeller adjusting washer and adjust the gap between the middle plate.</li> <li>④ Add the suction cover packing and adjust the gap between the impeller.</li> <li>⑤ Check the nameplate, and replace the product.</li> <li>⑥ Remove the obstruction or replace.</li> <li>⑦ Fully open the valve.</li> <li>⑧ Repair or replace the motor.</li> </ul>
Operates but does not aerate	<ul style="list-style-type: none"> <li>① Air inlet pipe or silencer is obstructed.</li> <li>② Valve is closed.</li> <li>③ Motor rotates in reverse direction.</li> </ul>	<ul style="list-style-type: none"> <li>① Remove the obstruction or replace.</li> <li>② Fully open the valve.</li> <li>③ Interchange the power supply leads (p. 10).</li> </ul>
Low performance or performance decreases	<ul style="list-style-type: none"> <li>① Air inlet pipe or silencer is obstructed.</li> <li>② Valve is too much squeezed.</li> <li>③ Impeller and/or suction cover are worn.</li> <li>④ A 60Hz product is used at 50Hz.</li> <li>⑤ Low voltage or voltage drop</li> </ul>	<ul style="list-style-type: none"> <li>① Remove the obstruction or replace.</li> <li>② Fully open the valve.</li> <li>③ Replace the worn parts.</li> <li>④ Check the nameplate, and replace the product.</li> <li>⑤ Provide the rated voltage, or make sure the cabtyre cable extension is the proper standard.</li> </ul>

## Disposal Product

Properly dispose of the product by disassembling it, presorting the contents, and sending them to the waste material treatment site.

The following information is required when ordering repairs or making other inquiries.

Product model	
Manufacturing number	
Purchase date	
Remarks	



**TSURUMI MANUFACTURING CO.,LTD.**

[www.tsurumipump.co.jp](http://www.tsurumipump.co.jp)