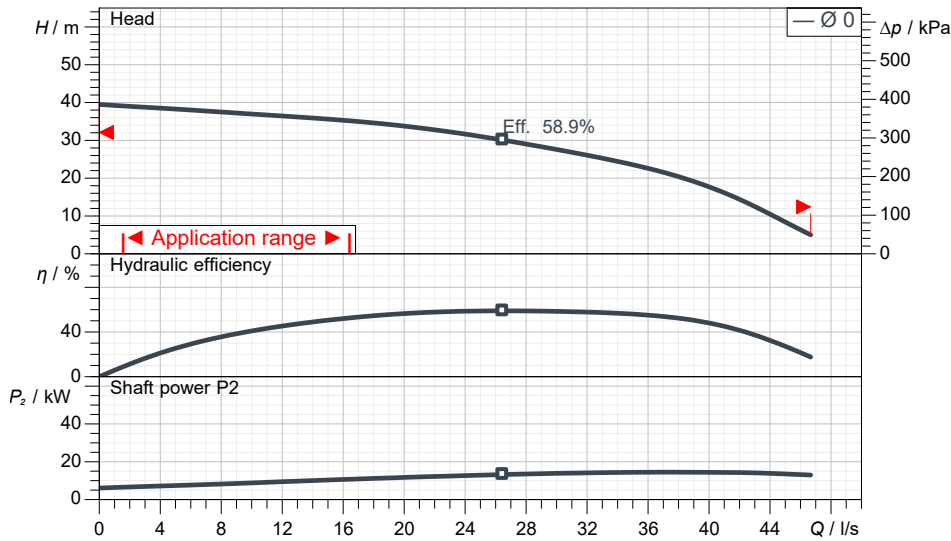

KTZ615-51 380-415V
Technical specification
3~ 50 Hz

Characteristic curves according to UNI EN ISO 9906:2012
 P₂<10kW: paragraph 4.4.2
 10kW<P₂<100kW: Grade 3B
 P₂>100kW: Grade 2B
 for pumps with standard material combination

Pump

Series	KTZ
Pump name	KTZ615-51 380-415V
Standard	

Motor data

Motor	SM1-2-15KTZ 400DYT
Rated voltage	380 V
Frequency	50 Hz
Motor phases	3~
Number of poles	2
Rated power P ₂	15.00 kW
Rated current	29.5 A
rpm	2890 1/min
Rated torque	49.6 Nm
Start*	Direct starting

Degree of protection	IP 68
Insulation class	F
Protection device	Circle thermal protector
Type of oil	Turbine oil VG32
Oil amount	0.82 l

Hydraulic

Free passage	
Impeller type	Semi-open impeller
Max. hydraulic efficiency	58.9 %
Discharge	150 mm
Curve tolerance	UNI EN ISO 9906:2012

Operating limits (standard pumps)

Max. ambient temperature	40 °C
Max. density treated liquid	1030 kg/m ³
pH treated liquid	5-9
Max. start per hour (equally distributed)	4
Wet/dry use	WET
Operating mode	S1

Construction materials

Motor enclosure	Gray Iron Casting 200
Shaft	420J2 Stainless Steel
Pump Casing	Gray Iron Casting 200
Impeller	High chromium casting
Suction Cover	Ductile Iron Casting 500
Painting	
Screws	304 Stainless Steel
Gaskets	NBR

Construction features

Power cable1	4C*5.5mm ²
Power cable2	N/A
Sheath	2PNCT.F
Control cable	N/A
Sheath	N/A
Cable length	8 m
Mechanical seals	H-30T
Weight*	147 kg

* cable and fixing system excluded

Monitoring features

Monitoring option	
leaking sensor -	N/A
monitoring equipment -	N/A

KTZ615-51 380-415V
Pump performance curves
3 ~ 50 Hz

Discharge 150 mm	Head	Capacity	Rated power 15.0 kW	Voltage 380 V	Current 29.5 A	rpm 2890 1/min
----------------------------	-------------	-----------------	-------------------------------	-------------------------	--------------------------	--------------------------

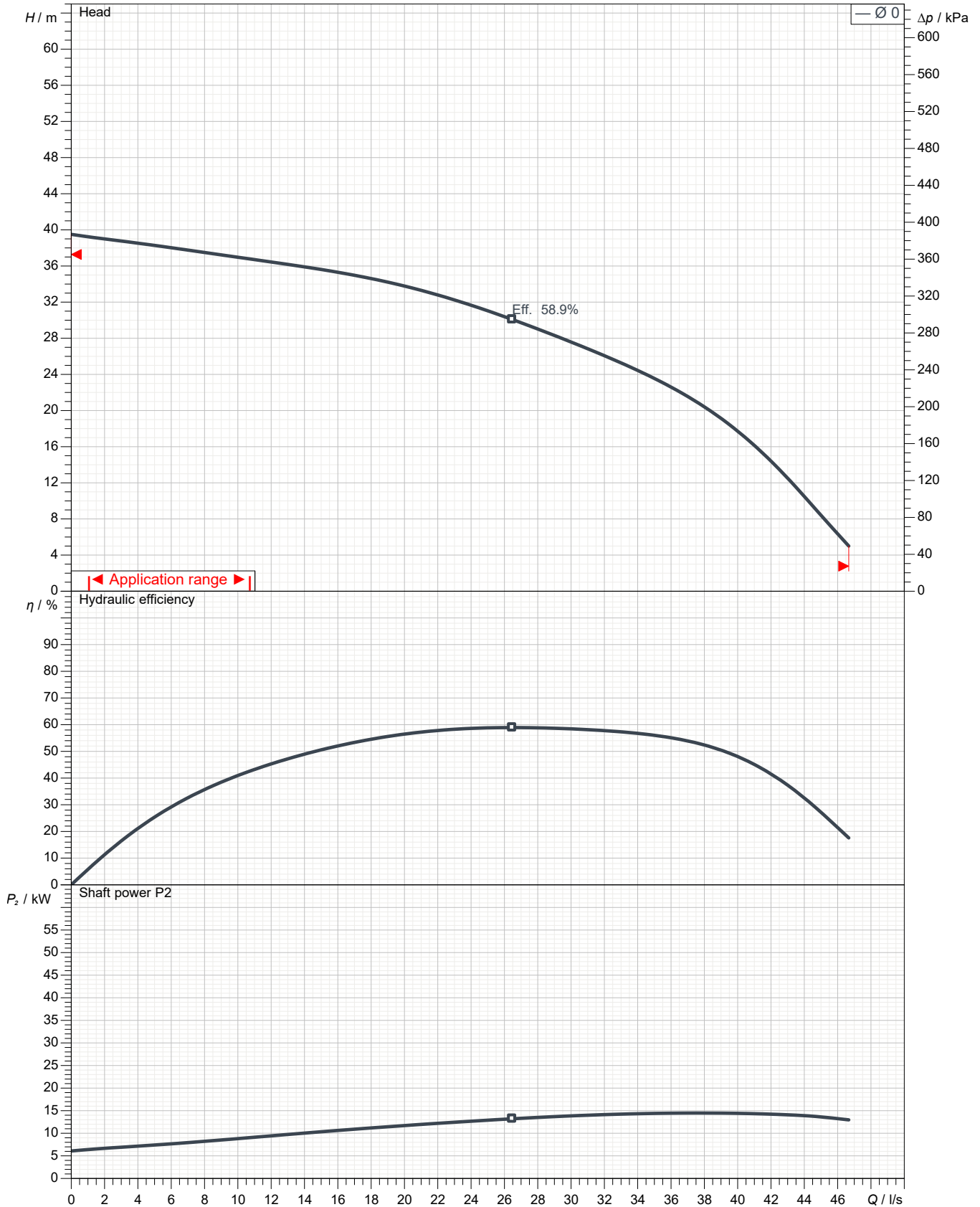

Characteristic curves according to UNI EN ISO 9906:2012 for pumps with standard material combination
 P₂<10kW: paragraph 4.4.2
 10kW<P₂<100kW: Grade 3B
 P₂>100kW: Grade 2B

DIMENSION DRAWING		No.	No.	A-22918-3
TYPE	Submersible Dewatering Pump	MODEL	KTZ611 -53/63	KTZ615 -51/61

MODEL	Approximate Weight (※)
KTZ611-53/63	133kg
KTZ615-51/61	146kg

※excluding cable

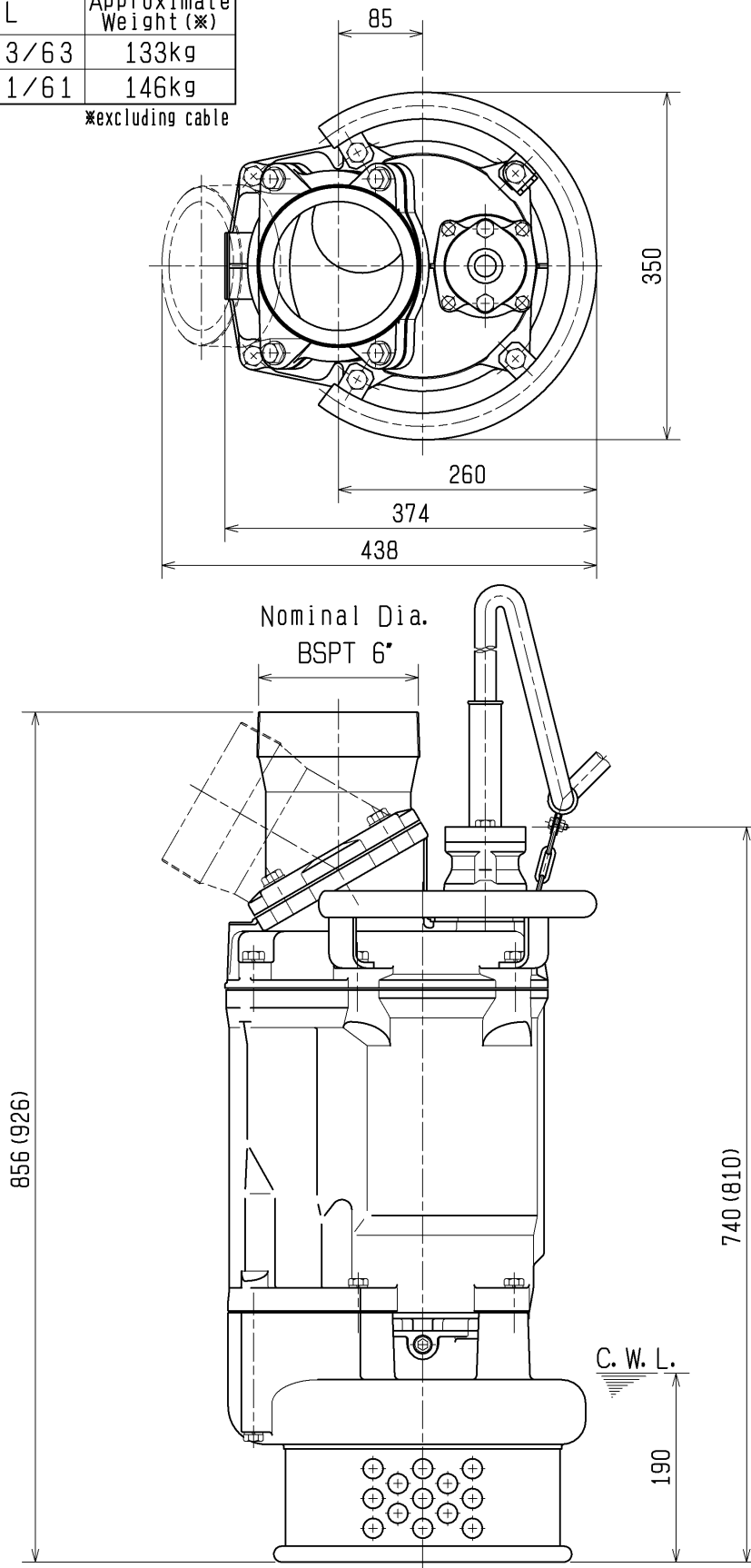

The Figure in () shows the dimensions of KTZ615-51/61.

C. W. L. :Continuous running Water Level

TSURUMI MFG. CO., LTD

unit:mm

Created on: 2025-01-20

SECTIONAL DRAWING		No.	No.	A-23812-3
TYPE	Submersible Dewatering Pump	MODEL	KTZ415 -51/61	KTZ615 -51/61

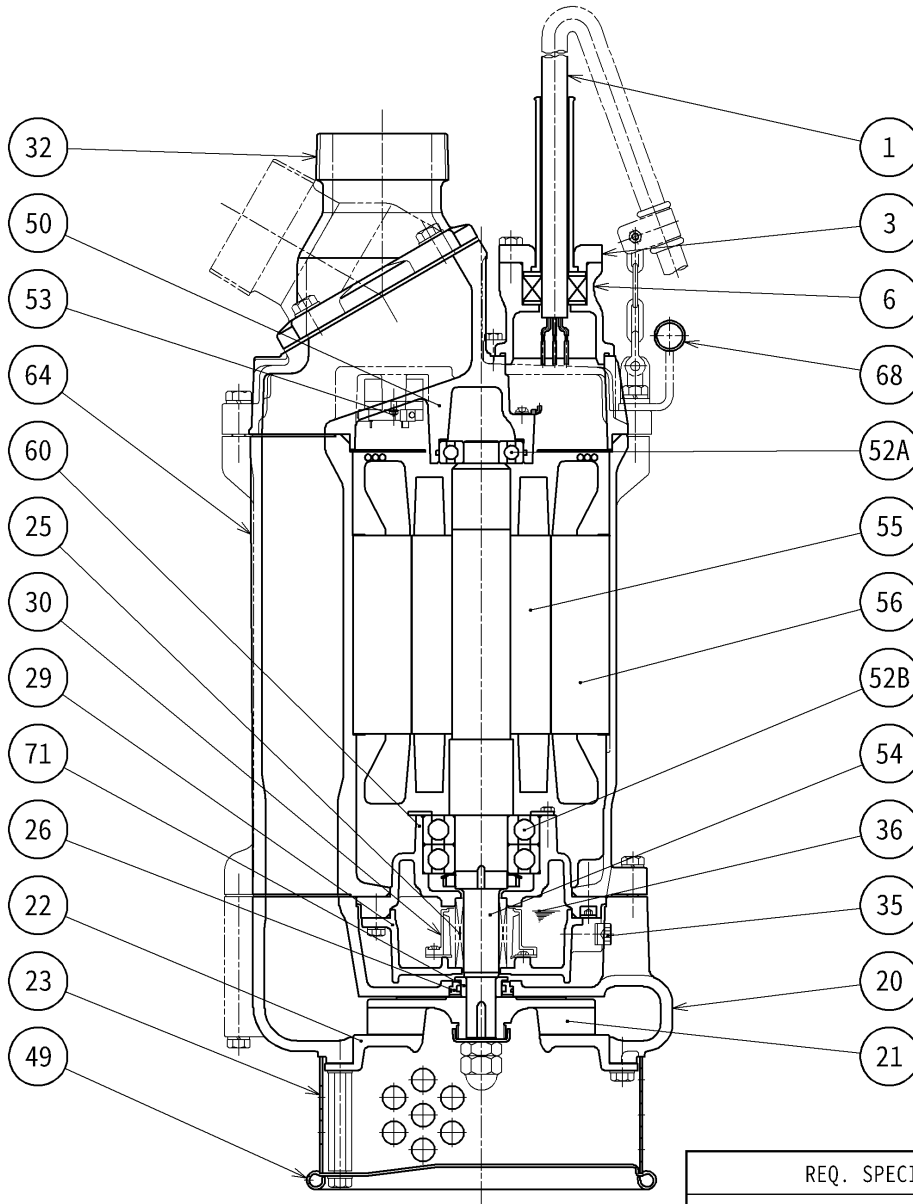

REQ. SPECIFICATION	

No.	DESCRIPTION	Q'TY	MATERIAL / NOTE	No.	DESCRIPTION	Q'TY	MATERIAL / NOTE
1	Cabtyre Cable	1	Chloroprene Sheath	49	Bottom Plate	1	Steel Sheet
3	Gland	1	Gray Iron Casting 200	50	Motor Bracket	1	Gray Iron Casting 200
6	Stuffing Box	1	Gray Iron Casting 200	52A	Upper Bearing	1	6306ZZC3
20	Pump Casing	1	Gray Iron Casting 200	52B	Lower Bearing	1	6309ZZD2C3
21	Impeller	1	Chromium Iron Casting	53	Motor Protector	1	
22	Suction Cover	1	Ductile Iron Casting 500	54	Shaft	1	420J2 Stainless Steel
23	Strainer	1	Steel Sheet	55	Rotor	1	
25	Mechanical Seal	1	H-30T	56	Stator	1	
26	Labyrinth Ring	1	304 Stainless Steel	60	Bearing Housing	1	Gray Iron Casting 150
29	Oil Casing	1	Gray Iron Casting 200	64	Motor Frame	1	Gray Iron Casting 200
30	Oil Lifter	1	Plastic	68	Handle	1	Carbon Steel Pipe & Structure Steel
32	Hose Coupling	1	Gray Iron Casting 200	71	Shaft Sleeve	1	403 Stainless Steel
35	Oil Plug	1	304 Stainless Steel				
36	Lubricant		Turbine Oil(ISO VG32)				

TSURUMI MFG. CO., LTD.

Created on: 2025-01-20

All data shown are not binding. Tsurumi reserves the right to change data and dimensions without notice.