

SPECIFICATIONS	Model	50U21.5							
		U-series 1.5kW, 3-phase							
<p>Type of Pump Submersible cast iron vortex pump suitable for pumping sewage, wastewater, storm water, etc.</p> <p>Type of Fluid Sewage, wastewater, and water carrying solid matters</p> <p>Temperature: 0 to 40°C (High temperature model available on special request)</p> <p>Discharge Bore 50mm</p> <p>Motor Output 1.5kW</p> <p>Power Supply Three-phase</p> <p>Starting Method Direct on Line</p> <p>Motor Continuous-duty rated, dry-type induction motor</p> <p>Insulation Class: F Degree of Protection: IP68</p> <p>No. of Poles & Speed (Synchronous Speed) 2-pole, 3000/3600min⁻¹ (50/60Hz)</p> <p>Power Supply Voltages & Rated Currents</p> <table border="0"> <tr> <td>50Hz</td> <td>60Hz</td> </tr> <tr> <td>380V – 3.5A</td> <td>220V – 6.0A</td> </tr> <tr> <td>400V – 3.5A</td> <td>380V – 3.4A</td> </tr> <tr> <td>415V – 3.5A</td> <td>440V – 3.2A</td> </tr> </table> <p>Power Cable Sheath: PVC Standard Length: 6m 200 to 600V supply: 1 × 4 × 1.25mm², O.D. 11.1mm</p> <p>Dry Weight (excluding cable) Free Standing Type: 30kg Guide Rail Fitting Type: 35kg</p>	50Hz	60Hz	380V – 3.5A	220V – 6.0A	400V – 3.5A	380V – 3.4A	415V – 3.5A	440V – 3.2A	<p>Impeller Vortex impeller, dynamically balanced</p> <p>Solids Passage 50Hz – ϕ35mm 60Hz – ϕ35mm</p> <p>Cable Entry with Anti-Wicking Block Watertight cable entry with strain-relief device. The anti-wicking block prevents water incursion due to capillary action should the power cable be damaged or the end submerged.</p> <p>Bearings Permanently lubricated, deep-groove, double-shielded C3 ball bearings</p> <p>Shaft 420 stainless steel</p> <p>Shaft Seal (Mechanical Seal) Furnished with a double-face mechanical seal located in oil chamber. Both upper and lower seal faces always run in a clean environment.</p> <p>Upper Seal Faces: Ceramic + Carbon Lower Seal Faces: SiC + SiC</p> <p>Oil Seal (Lip Seal) Used as a “Dust Seal”, it protects the mechanical seal from abrasive particles.</p> <p>OIL LIFTER (Patented) Equipped in oil chamber. It forcibly supplies lubricating oil to the mechanical seal and continues to supply the oil to the upper seal faces even if lubricant falls below the rated volume.</p> <p>Type of Lubricating Oil & Volume Turbine Oil (ISO VG32), 840ml</p> <p>Motor Protection Device A circle thermal protector built in the motor housing. Directly cuts the motor circuit if excessive heat builds up or an overcurrent condition occurs in the motor.</p>
50Hz	60Hz								
380V – 3.5A	220V – 6.0A								
400V – 3.5A	380V – 3.4A								
415V – 3.5A	440V – 3.2A								
<p>Optional Accessories</p> <p>TOS Set (Guide Rail Fitting Type)</p> <ul style="list-style-type: none"> • Duckfoot Bend • Guide Support • Guide Hook • Lifting Chain 5m (with Shackles) • JIS 10kg/cm² Screwed Flange <p>External Leakage Sensor</p>									
TSURUMI MANUFACTURING CO., LTD.									

NO. A-11608-1

PUMP PERFORMANCE CURVES

TYPE Sewage Submersible Vortex Pump	MODEL 50U (A/W) 21.5 -54 TOS50U (A/W) 21.5 -54	FREQUENCY 50 Hz
--	---	-----------------

CUSTOMER'S NAME _____

EQUIPMENT TITLE _____

NO. _____

	STANDARD SPECIFICATIONS	REQUIRED SPECIFICATIONS
DISCHARGE BORE	50 mm	mm
TOTAL HEAD	15 m	m
CAPACITY	0.2 m ³ /min	m ³ /min
MOTOR OUTPUT	1.5 kW	kW
PHASE × VOLTAGE	3 φ × V	φ × V
CURRENT	A	A
POLES / REVOLUTION	2 P / S. S. 3000 min ⁻¹	P / min ⁻¹
STARTING METHOD	DIRECT ON LINE	
INSULATION CLASS	F	

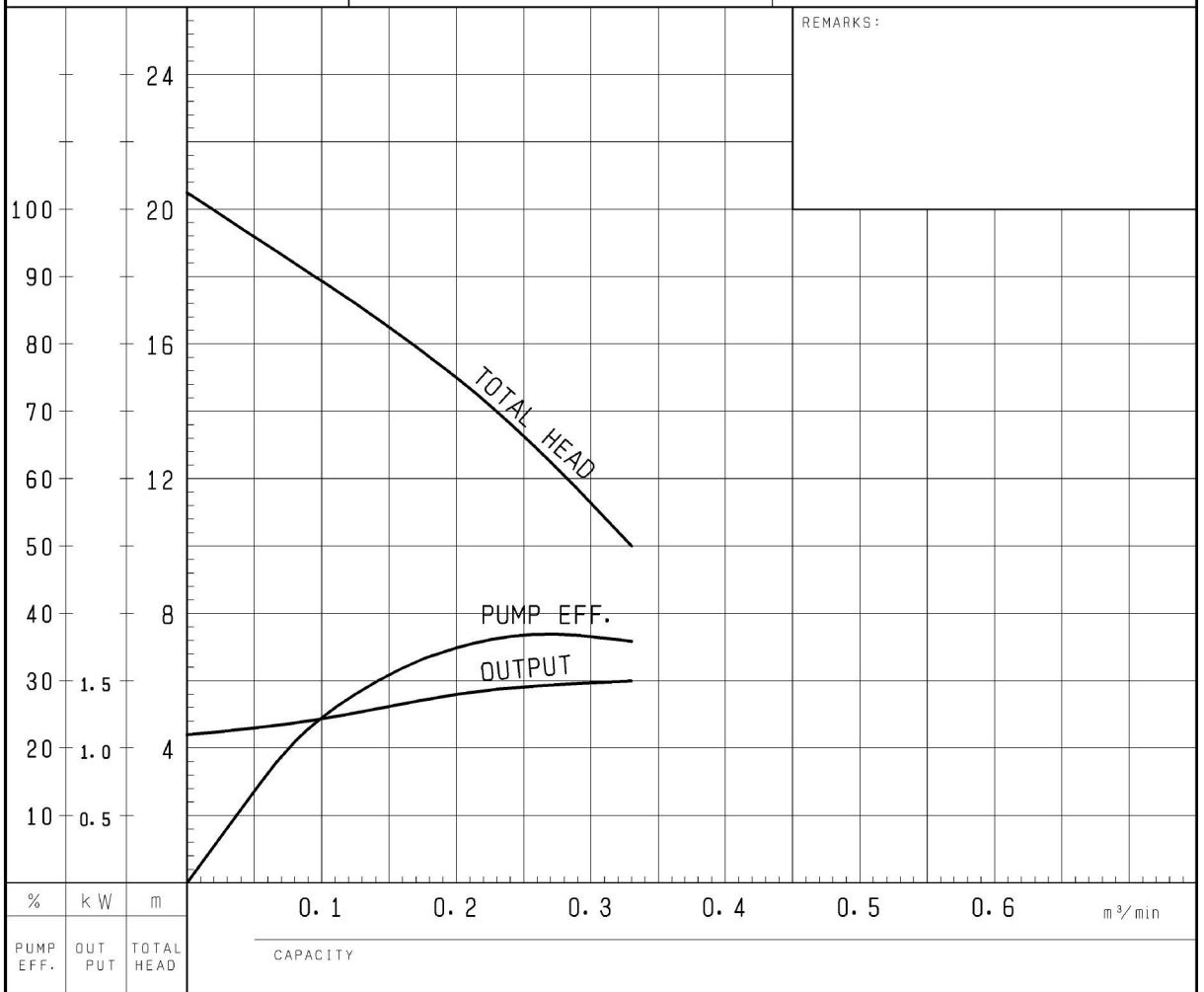

TSURUMI MFG. CO., LTD.

DIMENSION DRAWING		No.	No. A-11614-2
TYPE	Sewage Submersible Vortex Pump	MODEL	50U21.5 -54/64

Approximate Weight (※)
30kg
※excluding cable

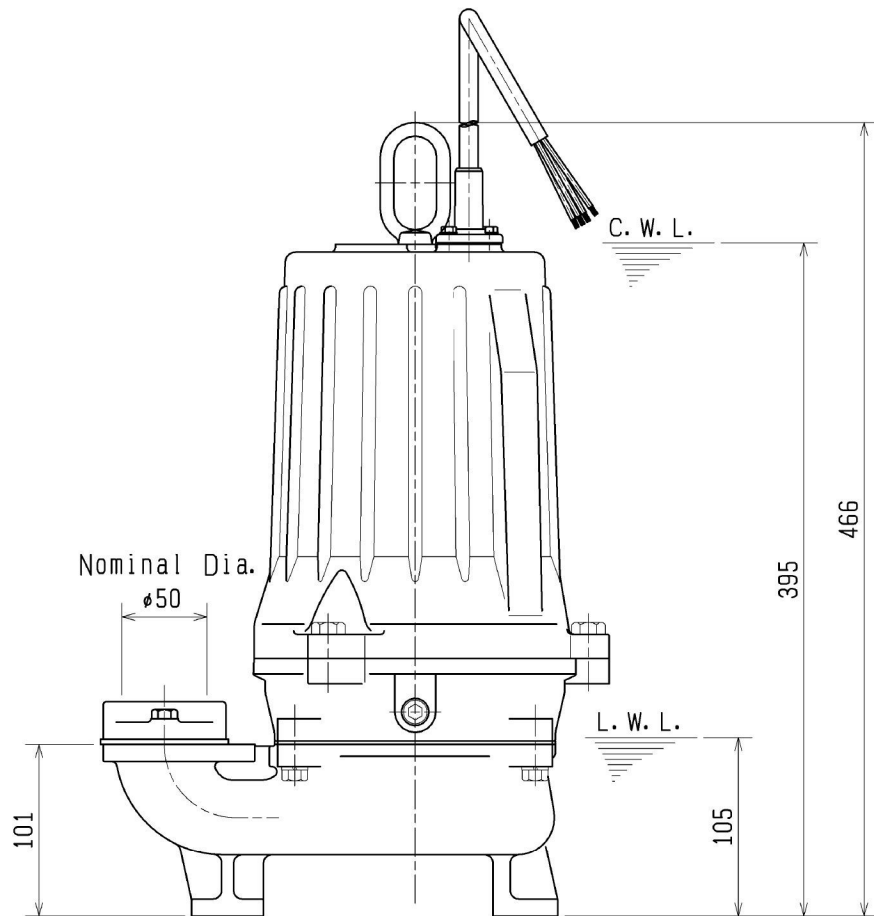
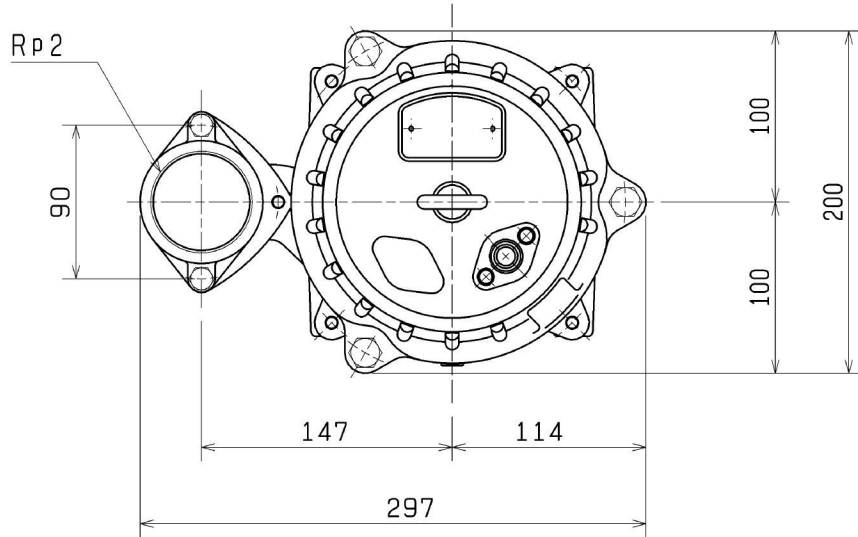

C.W.L. :Continuous Running Water Level
L.W.L. :Lowest Running Water Level

SECTIONAL DRAWING		No.	No.	A-11623-3
TYPE	Sewage Submersible Vortex Pump	MODEL	50U21.5 -54/64	

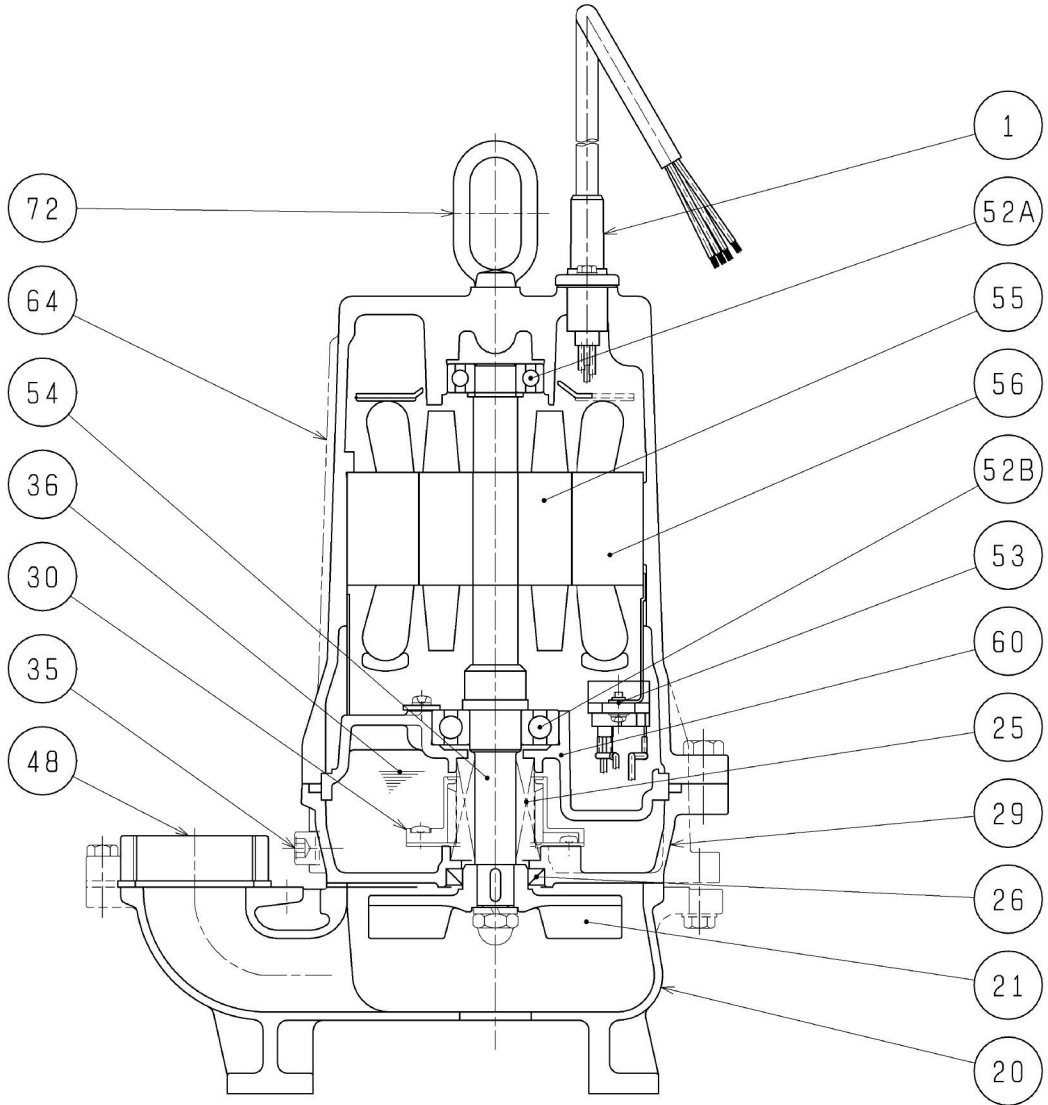

REQ. SPECIFICATION	

* the wetted part

No.	DESCRIPTION	QTY	MATERIAL / NOTE	No.	DESCRIPTION	QTY	MATERIAL / NOTE
1	Cable	1	PVC Sheath	52B	Lower Bearing	1	6305ZZC3
20	Pump Casing	1	Gray Iron Casting	53	Motor Protector	1	
21	Impeller	1	Gray Iron Casting	54	Shaft	1	Stainless Steel 420J2(※)
25	Mechanical Seal	1	H-20A	55	Rotor	1	
26	Oil Seal	1	TC32488	56	Stator	1	
29	Oil Casing	1	Gray Iron Casting	60	Bearing Housing	1	Gray Iron Casting
30	Oil Lifter	1	Plastic	64	Motor Frame	1	Gray Iron Casting
35	Oil Plug	1	Stainless Steel 304	72	Eye Bolt	1	Stainless Steel 304
36	Lubricant		Turbine Oil (ISO VG32)				
48	Screwed Flange	1	Gray Iron Casting				
52A	Upper Bearing	1	6204ZZC3				